



**Zimmer® ITST®
Intertrochanteric/
Subtrochanteric
Fixation System**

MIS and Standard
Surgical Technique



Surgical Technique for Fixation with ITST Intramedullary Nail System

This technique is written for standard or MIS procedure. Differences between the standard and MIS techniques are noted.

Table of Contents

Indications	2
Contraindications	2
Surgical Technique	3
Preoperative Planning	3
Patient Positioning	3
Reduction	4
Radiographic Control	4
Prep and Drape	4
Starting Point and Steinman Pin Insertion and Incision Using Long Cannulated Awl	5
Incision	5
Creating the Entry Portal	5
Guide Wire Placement	6
Measure	6
Reaming	7
Guide Assembly	8
Nail Assembly	8
Nail Insertion	9
Monitoring Insertion	10
Screw Options	10
Lag Screw Positioning	11
Lag Screw Preparation	12
Lag Screw Insertion with ITST Compression Device	15
Standard Lag Screw Insertion (Optional)	16
Anti-Rotation Screw Insertion	17
Distal Screw Fixation – 180mm/Short Nails	18
Distal Screw Fixation – Long Nails – Freehand Technique	20
Completion	22
Closure and Postoperative Care	24
Extraction	24
Implant and Instrument Case Options	25

The *ITST* Intramedullary Nail System is designed to treat comminuted, proximal and distal fractures of the femur, including, the Intertrochanteric and Subtrochanteric regions. The implant supports the anatomic reduction and internal fixation of the femoral head and neck.

The *ITST* Intramedullary Nail System features a sliding or non-sliding Lag Screw. System includes options for dynamic and static distal locking.

Indications

The *ITST* Intramedullary Nail is indicated for use in a variety of femoral fractures, such as:

- Subtrochanteric Fractures
- Intertrochanteric Fractures
- Comminuted Fractures
- Segmental Fractures
- Fractures with Bone Loss
- Proximal and Distal Fractures
- Nonunions

WARNING: The surgeon should be aware that this device is not indicated for use in osteoporotic bone, or nonanatomic reductions. Use of this device in those situations and/or improper placement of the nail-screw construct could increase the risk of failure or cut out of the implant.

Contraindications

Contraindications include:

- Femoral fractures involving the knee joint
- A medullary canal obliterated by a previous fracture or tumor
- Femoral shaft having grossly abnormal, excessive bow (i.e., curvature deformity)

The implant is contraindicated for use in medial neck fractures. This implant may not provide the required/desired stability when used to treat some femoral neck fractures types.

Overt systemic infection is an absolute contraindication. For patients that exhibit any of the following, systemic infection must be ruled out to minimize the potential hematogenous spread to the implant site:

- Fever and/or local inflammation signs
- Rapid joint destruction or bone absorption apparent on roentgenograms
- Elevation of sedimentation rate or C reactive protein unexplained by other diseases
- Elevation of White Blood Cells (WBC) and/or marked shift in WBC differential

Use of this device is contraindicated in patients with active infection at sites such as the genitourinary tract, pulmonary system, skin, or other sites because hematogenous spread may occur. The foci of infection must be treated and the infection resolved prior to surgery. Routine prophylactic antibiotic treatment immediately before, during, and after surgery may be especially useful for these patients.

Surgical Technique

Preoperative Planning

The *ITST* Fixation System implants are designed to place the Lag Screw at 130° with 15° of anteversion on the long nails, to accommodate the most common anatomic femoral neck angle. A/P and lateral C-arm images should be obtained prior to the surgical procedure.

NOTE: The suitability of this implant for the patient should be determined by templating prior to surgery using X-rays of the affected femur.

An A/P preoperative X-ray should be taken of the contralateral hip or of the affected limb once an anatomic reduction has been achieved. X-rays taken at a 36-inch distance from the source result in 10-15 percent magnification of the bone. An Ossimeter, which takes this magnification into account, should be used to help determine the actual nail length and diameter to be used. The angle of the intersection of the femoral shaft axis and femoral neck axis should be observed. The *ITST* Implant Templates reflect a 15 percent magnification of actual size.

Patient Positioning

The patient may be placed in either the supine (free legged or traction) or lateral (traction) position.

(1) SUPINE FREE LEGGED – Place the patient supine on a radiolucent table (Fig. 1). The table should not have a central pole or metal sidebars. Place the patient's buttock next to the edge of the table with a radiolucent bump (not a bean bag) under the buttock. The eccentric position and elevated buttock improves starting site position and reduces drape encroachment. Furthermore, the elevated buttock enhances fluoroscopic lateral viewing of the femoral head and neck. The ipsilateral upper trunk and extremity should angle towards the contralateral shoulder. The ipsilateral arm should be placed above the chest on an arm holder or on a pillow with stockinet. This upper extremity placement improves starting point entry and unencumbered implant insertion.

(2) SUPINE TRACTION ON FRACTURE TABLE – Place the patient supine on the fracture table (Fig. 2). Pad all areas of potential pressure. Flex and abduct the non-injured leg onto a well padded leg holder. Or, place the non-injured leg into a scissor type position.



Fig. 1

Position the buttock of the injured leg as close to the edge of the table as possible. Some tables will allow for an eccentric peroneal post connection to the table. Make sure the peroneal post is padded and wide in order to dissipate the pressure on the groin area.

Place the injured leg into skeletal traction (distal femoral or proximal tibial) or boot-traction. The ipsilateral arm should be placed above the chest on an arm holder or on a pillow with stockinet.

(3) LATERAL TRACTION ON FRACTURE TABLE – Use the radiolucent table with a radiolucent peroneal post. Place the traction boots on the patient during anesthesia induction. Turn the patient in a lateral position, with the operative leg over the top of the peroneal post. Attach the boots to the table with straight traction applied through the boots.



Fig. 2

If heavy traction is necessary, a pin is placed in the distal femur and the knee is flexed, applying traction through the pin. Flex and adduct the operative leg. Straighten the non-operative leg in line with the body. Rotate the patella slightly inwards towards the floor, to help prevent an external rotation deformity. Bring the C-arm in perpendicular to the long axis of the femur. When moving proximally and distally, the entire C-arm is moved, to stay perpendicular to the long axis. To visualize the proximal femur and the head, rotate the C-arm 15° over the top and tilted 45° cephalad.

Patient Positioning for Standard Technique

The patient should be placed in either the supine or lateral decubitus position on the table. The sacral rest and perineal post should be well padded. In multiple trauma patients, the supine position may be used for easier access to the patient's airway, as well as to facilitate the treatment of other injuries. The supine position also facilitates fracture reduction and rotational alignment of the femur.

Reduction

It is critical to reduce the fracture before beginning the surgical procedure. An anatomic reduction or a slight valgus reduction of the femoral head and neck, should be seen in the A/P film. Occasionally, a slight sag of the fracture may be seen on the lateral view. This should be taken into consideration during the surgical procedure. Occasionally, flexion of the injured limb will facilitate sagittal reduction. As a rule of thumb, intertrochanteric fractures are locked into position with internal rotation of the leg. The patella should point towards the ceiling.

For Pertrochanteric or Subtrochanteric fractures (especially with involvement of the lesser trochanter) the fracture is reduced with the leg in external rotation. Oblique roll over or roll back fluoroscopic views can assist visualization of proper rotation. This is most important when considering the starting point of the Steinman Pins or cannulated awl into the femur.

Radiographic Control

NOTE: It is essential to obtain excellent A/P and lateral images of the femoral head and neck prior to beginning the surgery regardless of which patient position is used.

The use of image intensification or other x-ray imaging is required. The image intensifier should be sterile-draped and may be positioned from the contralateral or ipsilateral side of the operating table.

Confirm visualization of the hip as well as the shaft of the femur using image intensification before prepping and draping. Bend the patient's torso away from the affected extremity to improve access to the greater trochanter. If access to the greater trochanter is still inadequate, adduct the affected leg. However, to achieve proper alignment of the fracture, this adducted position must be corrected prior to insertion of the nail.

Prep and Drape

The prep includes the ipsilateral axilla, trunk, buttock, hip, thigh (circumferentially), and knee. The drape should extend up to the axilla with U-shaped drapes. The free trunk and buttock skin improves nail insertion and diminishes guide entrapment on the drapes. Furthermore, the free area increases the freedom for percutaneous insertion and incision closure. The drape should extend past the knee to allow for distal interlock insertion.

Prep and Drape for Standard Technique

Prep and drape similar to the MIS technique, although it is only necessary to drape proximally to the distal portion of the thoracic cavity for the standard technique, not all the way to the axilla. If the patient is obese, prep and drape to the axilla and use a more proximal entry point.

Fracture Site Reduction After Prep and Drape

An attempt at fracture site reduction should be performed initially to facilitate the starting site placement, central reaming, and nail-screw insertion. The rotation and alignment should have been performed before the prep and drape. In fractures with varus alignment despite traction, placement of the patient in a lateral position of the percutaneous reduction instruments can help assist the reduction. A spike pusher or tenaculum clamp can be inserted through a 25 to 30mm incision to realign the proximal fragment. The classic flexion, abduction, and external rotation of the proximal fragment requires reduction at this time. A spike pusher or tenaculum clamp in an anterior to posterior direction will help accomplish the reduction.

Starting Point and Steinman Pin Insertion and Incision Using Long Cannulated Awl

Palpate the line of the femur starting at the greater trochanter. Continue this line of insertion proximally until reaching the level approximating the iliac crest (more proximal with obese patients) (Fig. 3).



Fig. 3

Using a sterile marking pen, mark the line of intersection between these two lines; this corresponds to the insertion site. Insert the 3.2mm terminally threaded Steinman pin through the soft tissues. The correct starting point on the AP view is the medial half of the greater trochanter. The correct starting point on the lateral view corresponds to the central half of the femoral neck. An optional cannula can also be used to help guide the pin into the correct position. The cannula is inserted through a 25mm incision at the level of the iliac crest. The cannula can also be used to protect tissues while reaming.

Incision

Use a #15 blade to create an incision centered around the Steinman pin. The incision needs to be only 15mm-20mm in length.

Starting Point and Incision for Standard Technique

Begin the skin incision 1cm proximal to the tip of the greater trochanter, and extend it proximally for about 5cm in a longitudinal direction. Continue the incision down through the subcutaneous tissues and split the fascia lata.

Creating the Entry Portal

Insert the terminally threaded Steinman pin through the greater trochanter down to the level of the lesser trochanter (about 8cm). Ream using the 8mm trochanteric reamer (for comminuted fracture lines extending into or around the insertion site) followed by the 17mm trochanteric reamer (initially for fractures without fracture lines extending into the starting site). The reamers can be inserted freely through the soft tissues or through the cannula. The entry portal should be in line with the planned nail insertion and should line up with the femoral canal on the AP and lateral views (not aiming to the medial or anterior cortices).

OPTIONAL TECHNIQUE

A cannulated awl can be used instead of a guide wire to create the entry portal. Place the tip of the awl in the selected starting point (confirm using bi-planer fluoroscopy). Advance the awl through the greater trochanter into the canal in line with the planned nail insertion (Fig. 4).



Fig. 4

Guide Wire Placement

On the back table, attach the 3.0mm Bulb-tipped Guide Wire to the Wire Grip T-Handle, and tighten (Fig. 5). To aid in manipulation, bend the tip of the guide wire at about a 10 degree angle 5cm from the end.

CAUTION: If the guide wire is bent shorter than 5cm from the end of the wire and/or more than 10 degrees it may be difficult to remove from the nail. If the wire becomes lodged inside the nail, utilize the WIRE GRIP T-HANDLE and mallet to remove the guide wire from the nail.

NOTE: If using a cannulated awl, the 3.0mm Bulb-Tipped Guide Wire may be passed directly through the cannulated awl without the 45° bend (Fig. 6).

Insert the Guide Wire through the entry hole and manipulate it down the proximal femur across the fracture site. At the fracture site, manipulate the Guide Wire under C-arm control across the



Fig. 5

fracture site. If reduction of the abducted and flexed hip is difficult, place pressure on the proximal fragment, either with the hand or directly with a reduction rod or other instrument. An alternative technique is to reduce the fracture using the Reduction Instruments shown in Figure 7.

The reduction finger can also be used to assist in reduction if the surgeon creates an initial oblique starting portal. Once in the distal canal, pass the wire to the distal epiphyseal scar. Gently tap the guide wire into the dense distal bone, so that the wire will not retract with reamer removal.

Measure



Fig. 6

The surgeon determines the proper nail length using the Nail Length Gauge. Slide the gauge over the guide wire until the tip rests along the proximal aspect of the greater trochanter (Fig. 8). The proper nail depth will be determined by individual anatomy, varus or valgus reduction, and most importantly by the position of the lag screw within the central aspect of the femoral head.

Reaming

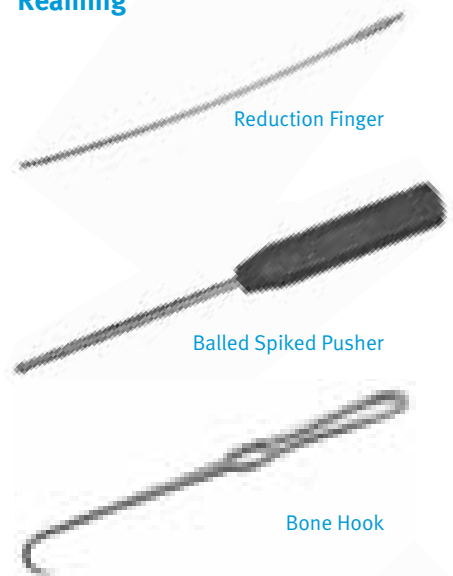

Fig. 7 Reduction Instruments



Fig. 8

The *ITST* MIS Cannula can be inserted into the incision to protect the soft tissue while reaming. Thread the Centering Bushing into the Cannula and place the Cannula firmly against the bone. Remove Centering Bushing. Ream the femoral canal sequentially in 0.5mm increments using the Long *Pressure Sentinel*® Intramedullary Reaming System (Fig. 9). Ream until cortical chatter is experienced. Based on bone quality and curvature of radius, nail diameter is 1-2mm less than the last reamer used.



Fig. 9

Over-reaming the canal by one or two millimeters may facilitate preparation of the bone to accommodate the implant. The trochanteric region should be reamed to 17mm using the Trochanteric Reamer for all patients to accommodate the implant and avoid separation or widening of known or unknown fracture lines (Fig. 10). Use caution in advancing the Taper Reamer. An alternative to reaming with the Taper reamer is to sequentially ream with a *Pressure Sentinel* Intramedullary Reamer to 17mm diameter.

Ream to the level of the lesser trochanter (or about 8cm depth), to accommodate the implant by advancing the Taper reamer into the proximal canal opening until the reamer flutes are sunk to the level of the lesser trochanter (Fig. 11). Confirm position using the C-arm.

Replace the Bulb-Tipped Guide Wire with the Smooth Guide Wire through the Exchange Tube.

If using a 3.0mm Ball-Tip Guide Wire that has a gold-coated end [Part numbers 00-2255-008-01 or 47-2255-008-11 (sterile)], the Ball-Tip Guide Wire can remain in place and removed after nail insertion. Otherwise, replace the Bulb-Tipped Guide Wire with the Smooth Guide Wire through an Exchange Tube.

NOTE: Reaming amounts will depend on the quality of the bone present, the minimum diameter of the femoral shaft, and the amount of femoral curvature present.

NOTE: If the Guide Wire becomes lodged within the reamer, use the Wire-Grip T-Handle to push the Guide Wire back into the IM canal.

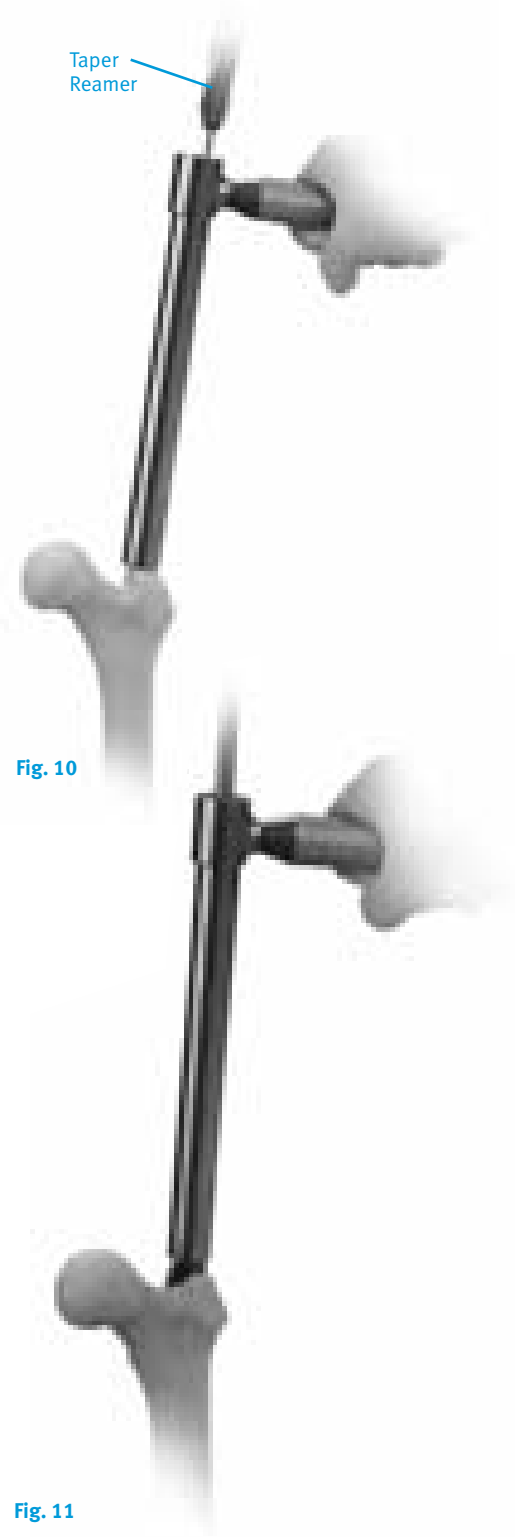
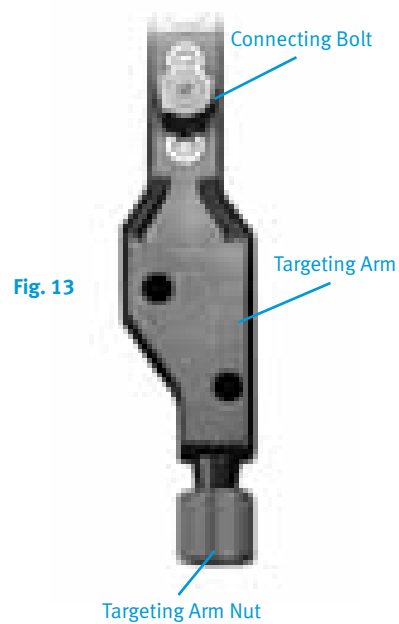
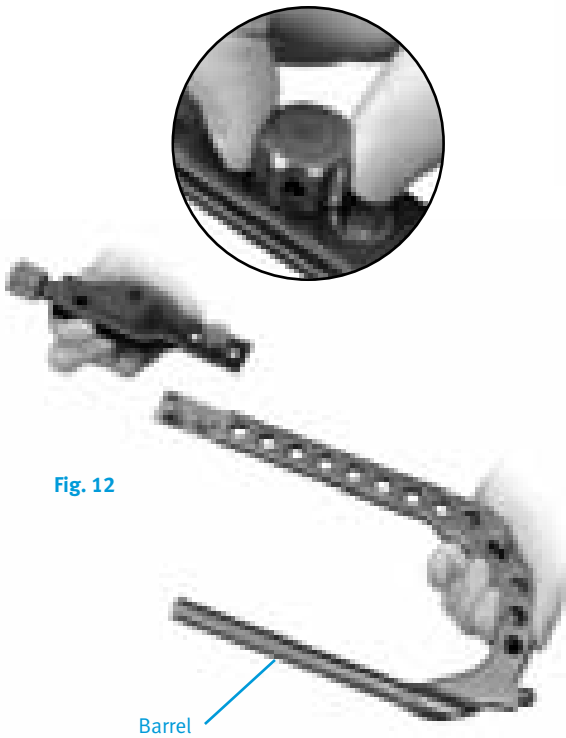

Fig. 10

Fig. 11

Guide Assembly

Thread the connecting bolt all the way through the blue Modular Targeting Arm. Attach the blue Modular Targeting Arm to the Barrel using the Connecting Bolt. Tighten the Connecting Bolt by hand (Fig. 12). Twist the Targeting Arm Nut on to the end of the Blue Targeting Guide in preparation for lag screw insertion (Fig. 13). The Nut should not be tightened at this point.



Nail Assembly

Select the appropriate size *ITST* Femoral Nail.

Slide the *ITST* Locking Bolt through the barrel (Fig. 14). Approximate the nail to the external “keys” on the barrel.

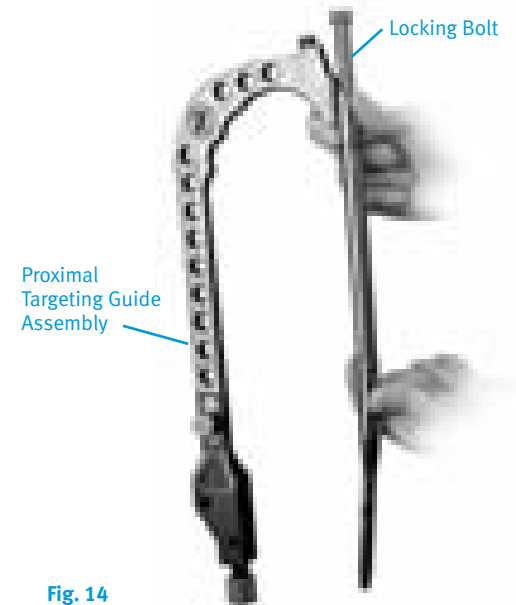

NOTE: The Guide is universal and it is critical that the nail be properly aligned with the Guide for a Left or Right implant. Line up the keys of the Guide with the keyways of the nail so that they fit snugly (Fig. 15).

Place the T-Handled Locking Bolt Inserter into the guide barrel (Fig. 16).

Toggle and rotate the Inserter slightly until it seats into the teeth of the Locking Bolt. The etched arrow at the proximal rim of the nail should be exactly aligned with the arrow on the distal rim of the Targeting Guide (Fig. 17). Using downward pressure on the Locking Bolt Inserter, thread the Locking Bolt into the threads of the proximal end of the nail until secured. Completely tighten.

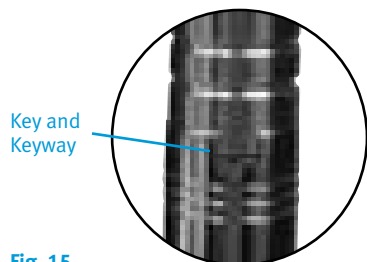

Fig. 15

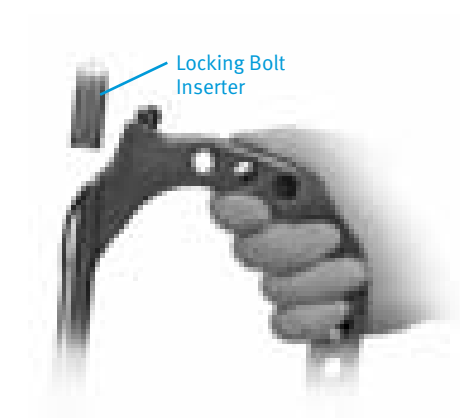

Fig. 16

Correct Alignment:
arrow to arrow

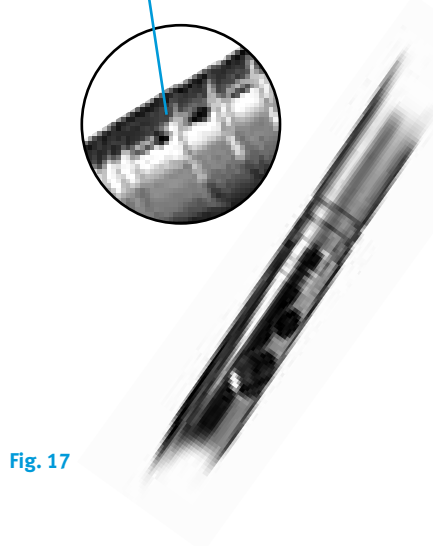

Fig. 17

Nail Insertion

NOTE: Prior to inserting the implant, insert the two sets of Drill and Screw Bushings into the appropriate holes in the Targeting Guide. Slide a drill or guide pin through the Bushings, and through the screw holes in the implant to assess correct instrument assembly (Fig. 18).

Nail may be inserted by hand. If insertion cannot be achieved by hand, please see note on page 10. Insert nail (assembled with targeting guide) into the femoral canal.

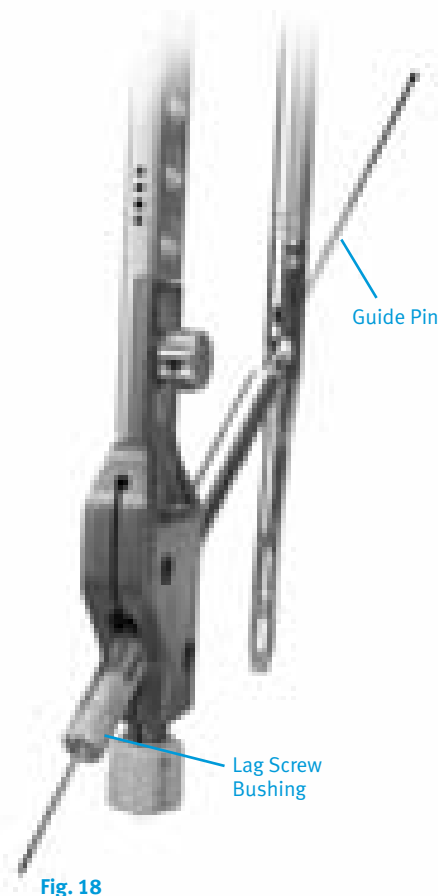

Fig. 18

Monitoring Insertion

Monitor the progression of the nail down the canal using a C-arm.

A percutaneous 3.2mm Threaded Guide Pin may be placed along the anterior axis of the femoral neck paralleling the femoral neck on the AP and lateral views to mark the correct anteversion.

Align the Targeting Guide parallel (on the lateral view) to the percutaneous pin to assure that accurate implant anteversion has been achieved. Check the final position of the implant using C-arm. If the nail fails to progress easily down the canal, remove it, and use a smaller nail, or over-ream the canal in 0.5mm increments until the implant passes more easily down the femoral canal. The surgeon should also check the status of the nail in the distal femur. If the nail is too long, a shorter nail should be used to avoid distal femoral cortical or articular penetration. If the curvature of the femur does not accommodate the nail, using a shorter or smaller nail will assist nail placement.

NOTE: If nail insertion can not be achieved by hand, thread the Small or Long Threaded Driver on the Barrel (Fig. 19). Insert the nail into the canal using a series of gentle impactions, if necessary, on the Threaded Driver until the nail is seated at the desired depth.

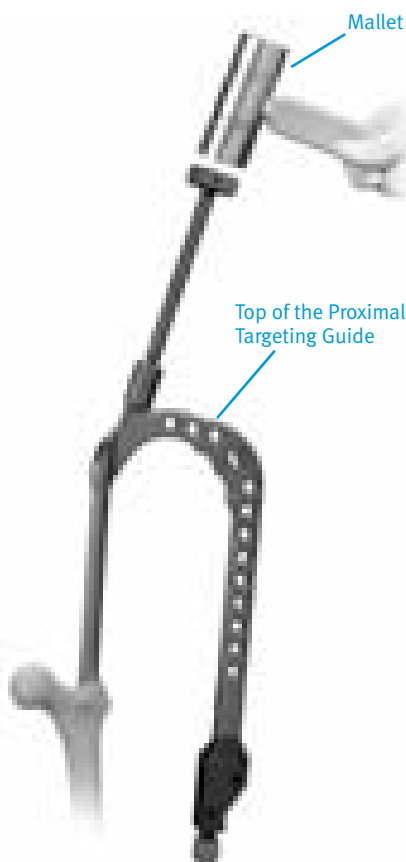

Fig. 19

CAUTION: Do not impact directly on the *ITST* Targeting Guide or Barrel.

Screw Options

The *ITST* Nail accommodates both an 11mm Lag Screw and a 6.5mm Anti-Rotation Screw. The Anti-Rotation Screw may be utilized in the case of certain fractures, where the bone stock and femoral neck/head bone stock is able to accommodate it. If only one screw is used, it must be the 11mm Lag Screw.

NOTE: The 6.5mm Anti-Rotation Screw may be used to enhance fracture stability if the femoral neck is able to accommodate it; however, it should not be used if there is any concern that the femoral head or neck bone will not accommodate it.

WARNING: Use of this system in osteoporotic bone or improper placement of the nail could increase the risk of failure or cut out of the implant.

Remember the goal of lag screw placement is perfect placement into the central position of the femoral head on the AP and lateral view.

Lag Screw Positioning

The projected path of the Lag Screw into the Femoral Head should be assessed using the C-arm (Fig. 20). This may be verified using the Screw Position Outrigger and the 3.2mm Threaded Guide Pin. Assemble the Outrigger into the Modular Targeting Arm and place a Threaded Guide Pin into the Anteversion Verification Hole in the barrel (Fig. 21). Verify under C-arm that the Guide Pin appears in the center of the femoral neck in a superior/lateral view. This will help prevent any parallax error. The outer aspect of the windowed arm of the Outrigger, which lies directly over the femoral neck, represents the superior and inferior position of the Lag and Anti-Rotation Screws (Fig. 22).

If the nail anteversion requires adjustment, move the nail up or down in the canal by hand or by gently impacting the Threaded Driver until the correct depth is achieved. Check the position of the nail with the C-arm. Adjusting nail depth may be useful in accommodating various femoral neck anatomies.

NOTE: If the C-arm is off axis, the alignment of the Outrigger may not accurately predict the position of Lag and Anti-Rotation Screws. In the event this occurs, adjust the position of the C-arm until it is on axis.

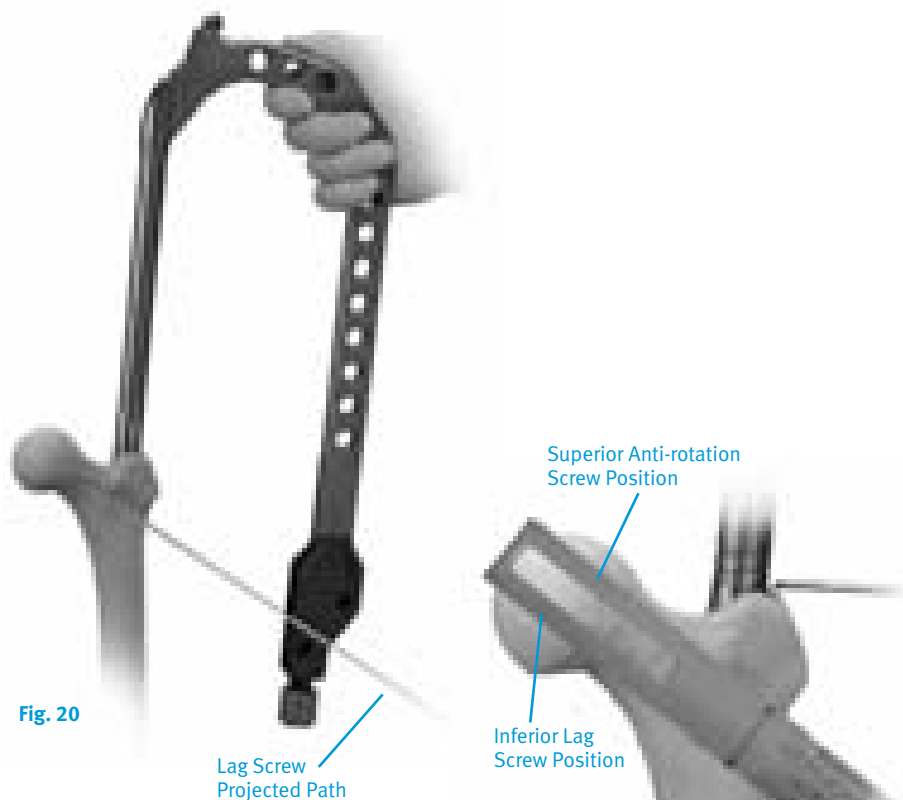

Fig. 20

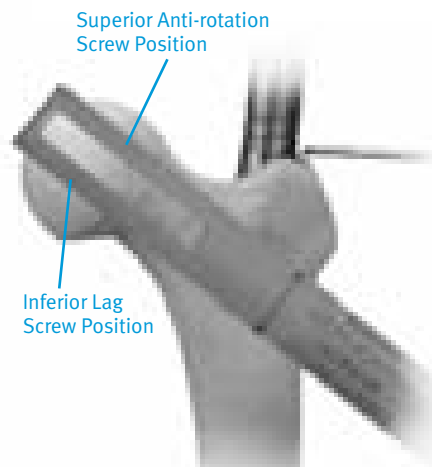

Fig. 22



Fig. 21

Lag Screw Preparation

NOTE: The 6.5mm Anti-Rotation Screw may be used to enhance fracture stability if the femoral neck is able to accommodate it.

Remove the 3.2mm Guide Wire. Assemble the Lag Screw Pin Bushing and Lag Screw Bushing together and place the assembly into the **inferior** screw hole in the Targeting Arm (Fig. 23). Assemble the 3.2mm Arm Pin Bushing, the 5.0mm Drill Bushing and the 8.0mm Screw Bushing and insert the assembly into the **superior** screw hole in the Targeting Arm (Fig. 24). When both bushings are inserted, the 8.0mm Drill Bushing will slide freely in the Targeting Arm. Make small incisions in the soft tissue and through the iliotibial band, down to the lateral cortex of the femur. Be certain that the bushings are firmly seated on the bone. Do not force the bushings or impact.

Insert a 3.2mm Threaded Guide Pin into the inferior set of bushings. Drill the Guide Pin to the level of the subchondral bone of the femoral head, without penetrating the femoral head cortex (Fig. 25). Insert a Guide Pin into the superior set of bushings. The Screw Inserter Adapter may be used with this Guide Pin to prevent impingement on the adjacent Guide Pin during insertion (Fig. 26). Drill the Guide Pin to the level of the subchondral bone of the femoral head, without penetrating the femoral head cortex. Assess the position of the Guide Pins using C-arm in the A/P and lateral planes.

NOTE: Ideally each Guide Pin should be situated well inside the femoral neck to allow adequate room for screw placement without contacting the cortical wall. If there is not sufficient cortical wall surrounding the Guide Pins on examination with the C-arm, the nail may be repositioned and implanted using only the Lag Screw.

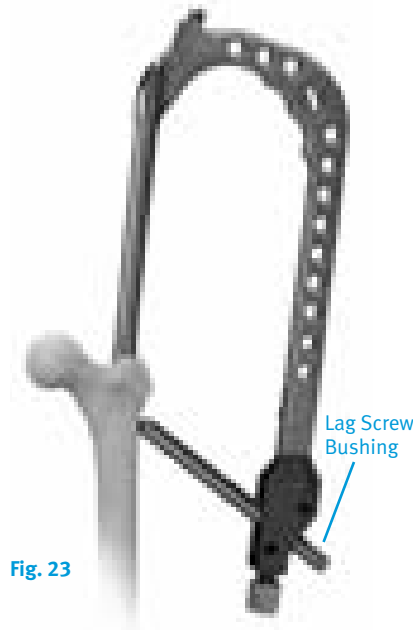

Fig. 23

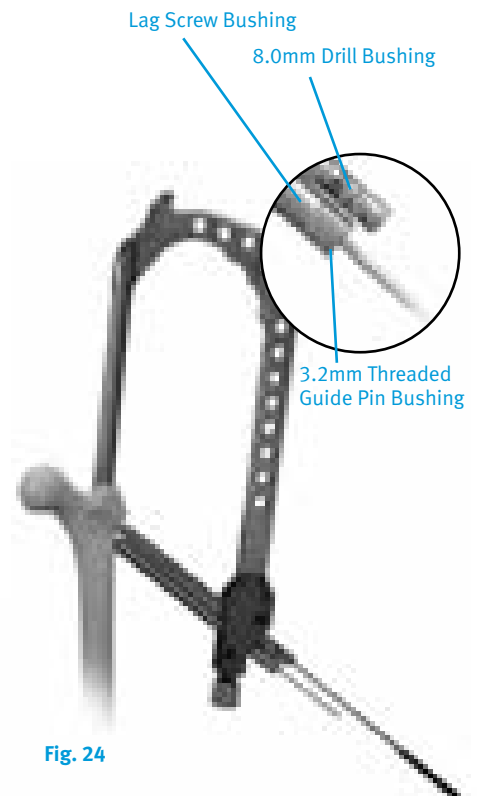

Fig. 24

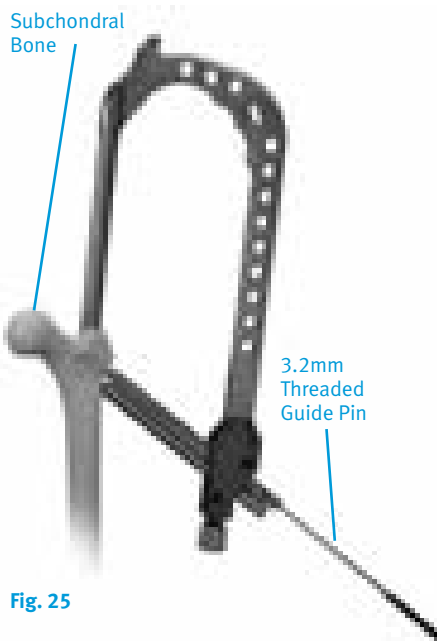

Fig. 25

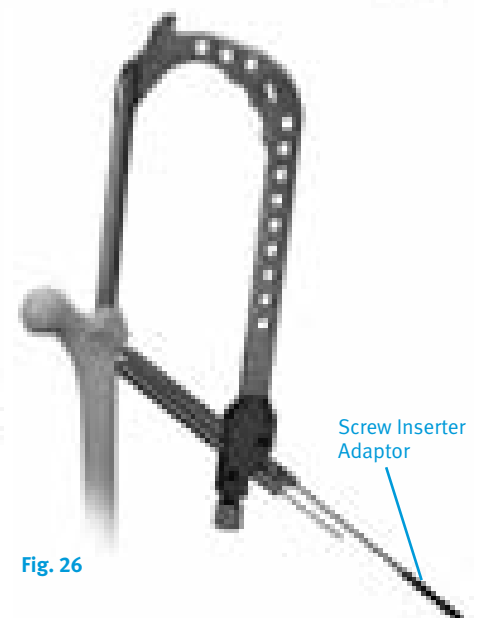

Fig. 26

Remove the Lag Screw Pin Bushing. Slide the Cannulated Depth Gauge over the lag screw Guide Pin, (i.e. the inferior of the two guide pins), until the gauge contacts the lateral aspect of the femur (Fig. 27). Assess that the Gauge is seated against the bone using the C-arm. Read and record the length of the guide pin from the calibrated depth gauge.

NOTE: This measurement designates the correct length of the Lag Screw to be implanted (Fig. 28).

Slide the Stop Assembly onto the *ITST* Lag Screw Reamer, keeping the gold portion of the Stop Assembly toward the cutting end of the reamer (Fig. 29). Move the Stop Assembly along the incremented lengths listed on the reamer. Align the threaded end of the Stop Assembly with the notch denoting the appropriate length.



Fig. 27

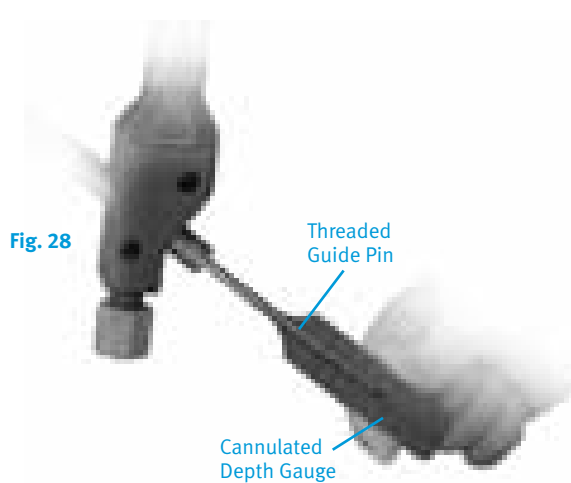
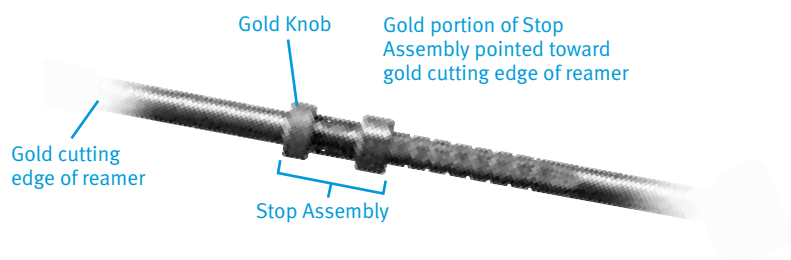

Fig. 28



Lag Screw Reamer



Fig. 29

When the Stop Assembly is fully seated, the arrow on the Stop Assembly will indicate the appropriate depth level. This “length” corresponds to the measurement obtained from the guide pin (Fig. 30).

Place the *ITST* Lag Screw Reamer over the Guide Pin and seat it against the femoral cortex. Under power, advance the reamer until the Stop Assembly stops against the Lag Screw Bushing (Fig. 31). Monitor progress of the reamer using the C-arm. Remove the reamer.

If necessary, assemble the Lag Screw Tap by locking the Stop Assembly at the level of the appropriate measurement, in the same fashion as the Lag Screw Reamer. Place the Lag Screw Tap over the Guide Pin and through the Lag Screw Bushing. Advance the tap until the Stop Assembly stops against the collar of the Lag Screw Bushing (Fig. 32). Confirm Tap position with the C-arm.

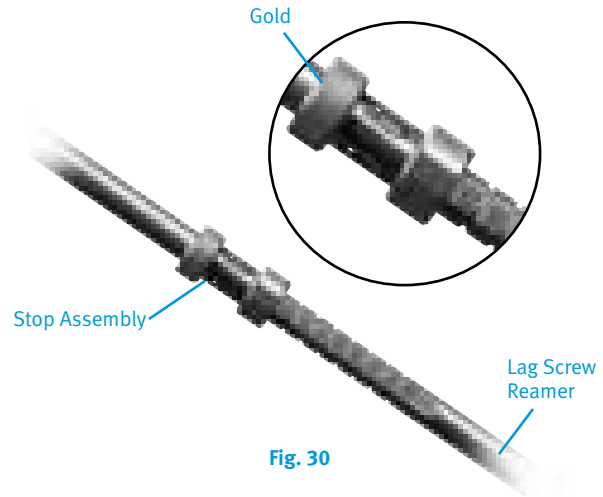

Fig. 30

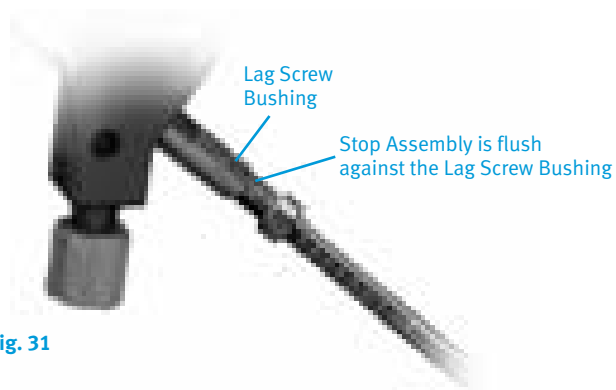

Fig. 31

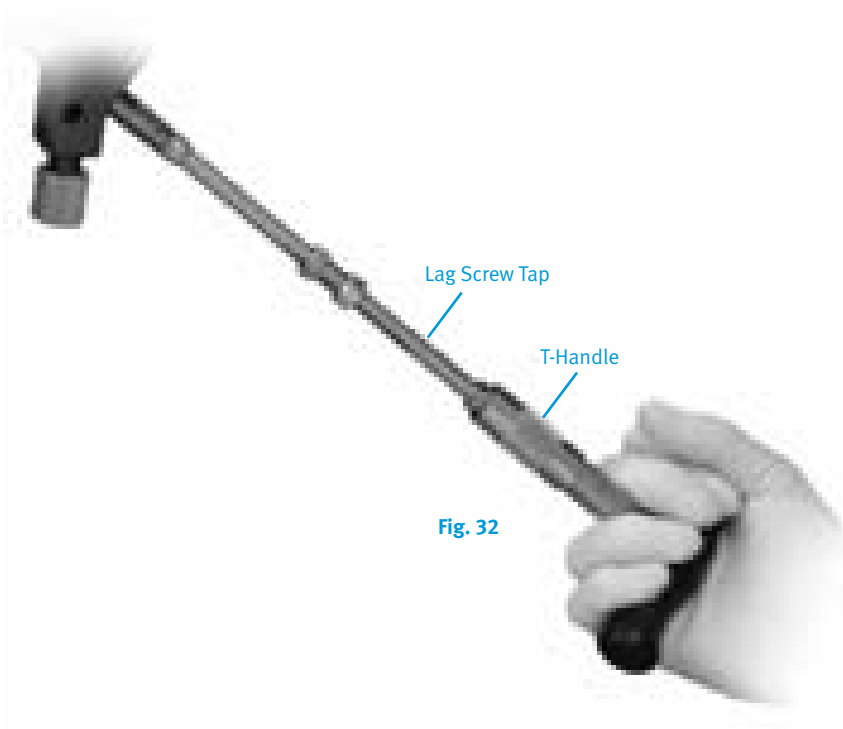

Fig. 32

Lag Screw Insertion With ITST Compression Device

If not using the ITST Compression Device, proceed to page 16.

Thread the Compressor onto the Lag Screw Compression Device T-Handle. Insert Compression Retainer through the Lag Screw Compression Device T-Handle (Fig. 33) and thread into the appropriate Lag Screw until it is securely fastened to the Lag Screw Compression Device T-Handle. Pass the Lag Screw Compression Device assembly through the Lag Screw Bushing and over the Guide Pin (Fig. 34). Thread Lag Screw to within 5mm of the subchondral bone, monitoring the Lag Screw advancement with the C-arm.

If planning to use a Nail Cap which prevents rotation or limits sliding, rotate the Lag Screw Compression Device T-Handle (Fig. 35) such that one of the four etched lines is in line with the vertical slot on the Targeting Guide.

After inserting the Lag Screw to the appropriate depth, confirm Lag Screw position using the C-arm. To begin compression of the femoral neck, advance the Compressor clockwise against the Lag Screw Bushing (Fig. 36). Continue to advance the Compressor while monitoring femoral neck compression using the C-arm, until the desired fracture reduction is achieved.

After reduction, unthread the Compression Retainer from the Lag Screw. After removing the Compression Retainer, the Lag Screw Compression Device Assembly can be removed. Remove the Superior Guide Pin and Bushings if used. If using ITST Global Long Nail, remove Targeting Guide using the Pin Wrench and Locking Bolt Extractor.



Fig. 33

(Replacement Part 00-2258-097-01)

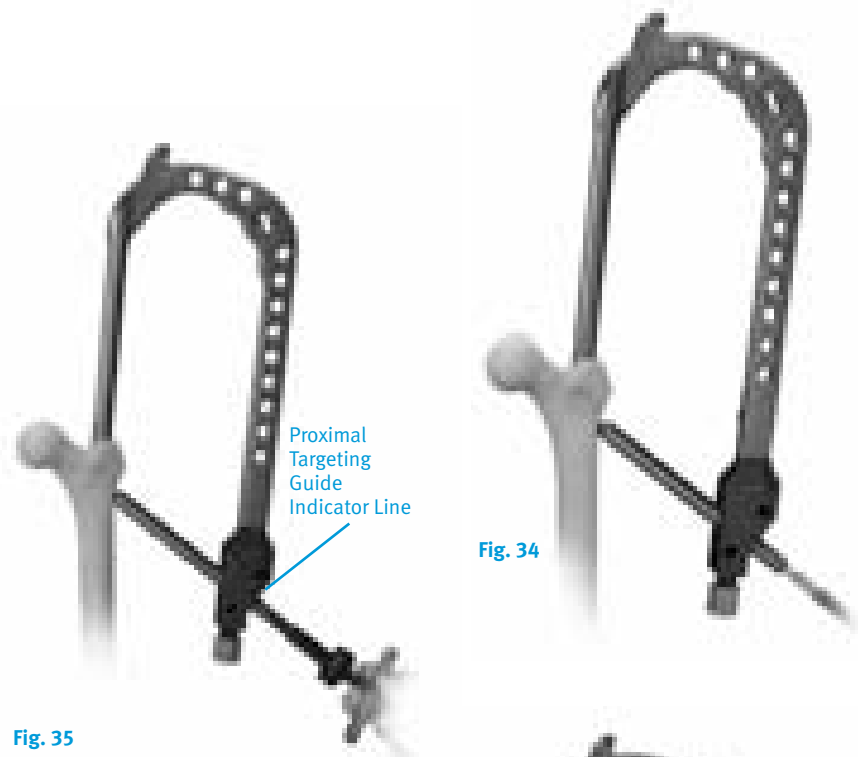

Fig. 34

Fig. 35



Fig. 36

Standard Lag Screw Insertion (Optional)

Thread the Inserter Link (Fig. 37) into the Lag Screw until securely fastened. Slide the Lag Screw Inserter Shaft over the Inserter Link (Fig. 38).

Insert this assembly over the Guide Pin. Thread the Lag Screw to within 5mm of the Subchondral bone. Rotate the Inserter Shaft (Fig. 39) and align one of the four etch lines on the Inserter Shaft with the vertical slot on the Targeting Guide (Fig. 48). Check the Lag Screw position using the C-arm. Leave the Inserter Link attached to the Lag Screw.

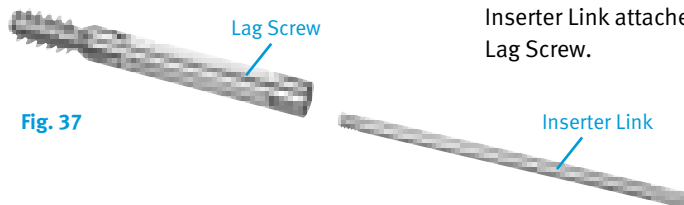

Fig. 37



Fig. 38

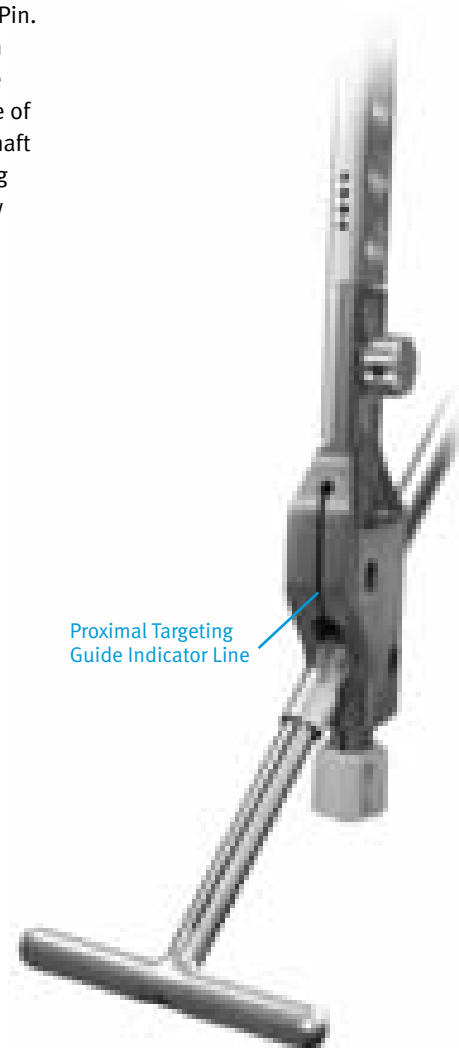

Fig. 39

Anti-Rotation Screw Insertion

Remove the 3.2mm Pin Bushing. Slide the Cannulated Depth Gauge over the Guide Pin, until the Gauge contacts the lateral aspect of the femur. Confirm the position of the Depth Gauge using the C-arm. Read the depth of the guide pin from the Cannulated Depth Gauge. The Anti-Rotation Screw length should be 15mm to 20mm shorter than the depth gauge measurement. This will provide the proper screw placement to help minimize femoral neck cutout¹ (Fig. 40). Remove the Guide Pin. Under C-arm control, drill into the femur with the 5.0mm Drill until the correct calibration on the drill is level with the outer collar of the Drill Bushing.

Remove the 5.0mm Drill Bushing and Drill. Insert the Anti-Rotation Screw using the 5.0mm T-Handle Screwdriver through the 8mm Screw Bushing and into the femoral head until seated. Placement of the screw should be monitored using the C-arm.



Fig. 40

¹ Baumgaertner, MR, et al., *J Bone Joint Surg. AM.* 1996 Sep; 78(9):1447-1448.

Distal Screw Fixation – 180mm / Short Nails

With the Proximal Targeting Guide still in place, retighten the Locking Bolt if necessary. Assemble the appropriate Drill Bushing (see Table 1) into the 8.0mm Screw Bushing, and place the nested bushings through one of the distal targeting holes in the *ITST* Modular Targeting Guide (Fig. 41). Make a small incision through the skin and fascia lata. Spread the soft tissue down to the bone. Advance the bushing until it contacts the lateral femoral cortex. Advance the appropriate size Drill through the bushings until both cortices of bone have been penetrated.

NOTE: If using the Calibrated 3.7mm or 5.0mm Drill, read calibrations from end of bushing to determine screw length.

Table 1.

ITST Global Nails 180mm	Diameter Distal Screw	Drill Size
10mm Nail	4.5mm Screw	3.7mm Drill
11mm Nail	5.5mm Screw	5.0mm Drill
12mm Nail	5.5mm Screw	5.0mm Drill
13mm Nail	5.5mm Screw	5.0mm Drill
14mm Nail	5.5mm Screw	5.0mm Drill
15mm Nail	5.5mm Screw	5.0mm Drill

ITST Global Nails 300-500mm	Diameter Distal Screw	Drill Size
10mm Nail	4.5mm Screw	3.7mm Drill
11mm Nail	5.5mm Screw	5.0mm Drill
12mm Nail	5.5mm Screw	5.0mm Drill
13mm Nail	5.5mm Screw	5.0mm Drill
14mm Nail	5.5mm Screw	5.0mm Drill



Fig. 41

OPTIONAL TECHNIQUE

Remove the Drill and Drill Bushing, and insert the *ITST* Screw Depth Gauge through the 8.0mm Screw Bushing until the gauge captures the far cortex of bone.

Read the measurement for the screw from the end of the depth gauge.

NOTE: Choose a screw length that is at least 2.5mm longer than the depth measured, to ensure that bicortical screw fixation is attained.

If the bone quality is good, it may be necessary to tap the channel using the 4.5mm Tap (Fig. 42).

Place the appropriate length Cortical Screw onto the 3.5mm T-Handle Hex Screwdriver and insert the screw into the bone through the 8.0mm Screw Bushing, until it is flush against the lateral cortex of the femur (Fig. 43). Confirm the position of the screw in the A/P and lateral views with the C-arm.

Place the second distal locking screw in the same fashion as the first.

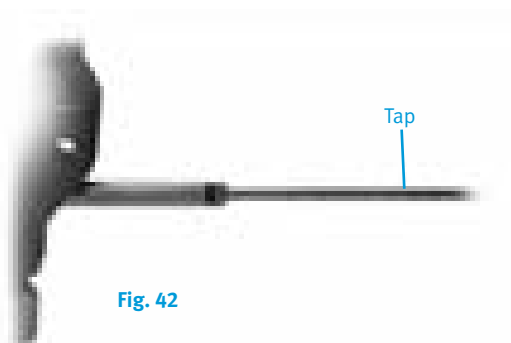

Fig. 42



Fig. 43

Distal Screw Fixation – Long Nails – Freehand Technique

The distal locking screws may be inserted with a freehand technique using the Freehand Targeting Device (Fig. 44). Insert a 3.7mm Drill (Color Code: Blue) for a 4.5mm screw, or insert a 5.0mm Drill (Color Code: Green) for 5.5mm screw into the Freehand Targeting Device. Finger tighten the set screw.

Choose the appropriate locking hole based on the need for dynamization. The superior locking hole on the *ITST* Nail is used for static locking, while the distal locking hole is used for dynamic locking. If static locking is preferred, but there is a potential need for later dynamization, insert screws in both locking holes. The locking screw in the static hole can then be removed to achieve dynamization later.

For success with this technique, proper placement of the lateral X-ray beam is critical. Position the C-arm so that the locking hole of the nail appears perfectly round on the monitor (Fig. 45 & 46).

When this is achieved, bring the tip of the 3.7mm Drill to the skin and use the C-arm to center it over the hole. Make a lateral stab wound opposite the appropriate locking hole, and dissect down to the bone. Bring the tip of the 3.7mm Drill to the bone and center it over the locking hole using the C-arm. Align the 3.7mm Drill with the axis of the X-ray beam. Drive the 3.7mm Drill into the bone and across the hole in the nail in line with the lateral X-ray beam (Fig. 47). Before drilling through the medial cortex, check the A/P and lateral C-arm image to assure that the drill is in the hole in the nail.

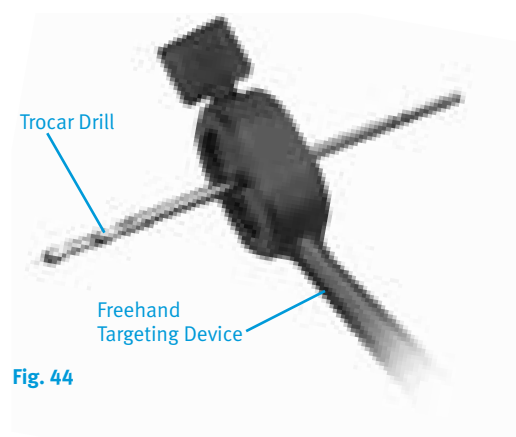
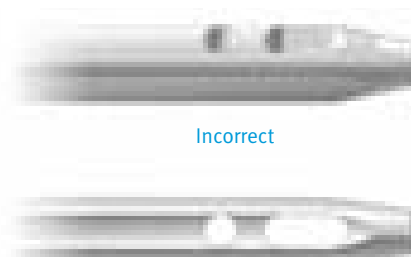

Fig. 44



Incorrect



Correct

Fig. 45



Incorrect



Correct

Fig. 46

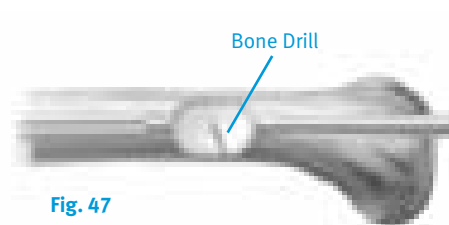

Fig. 47

Drill through the medial cortex (Fig. 48 & 49). Remove the Drill and insert the Distal Screw Depth Gauge (Fig. 50). The length of the screw is determined by reading it directly off the Distal Screw Depth Gauge.

NOTE: Select an appropriate length screw to ensure adequate engagement of the medial cortex.

Insert the appropriate size *M/DN*® Screw using the Distal Screwdriver (Fig. 51).

If desired, insert the second screw in the second locking hole of the nail in an identical manner. Check the position of both screws with the C-arm in the A/P and lateral planes (Fig. 52).

Bushings are available that can be used with the Freehand Targeting Device. A separate radiolucent Bushing Insert is available to aid in targeting.

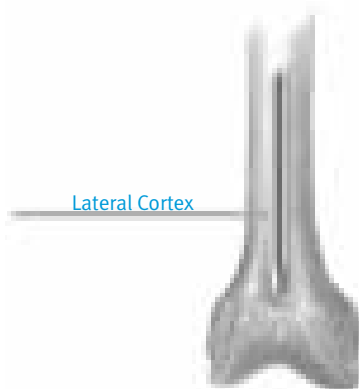

Fig. 48

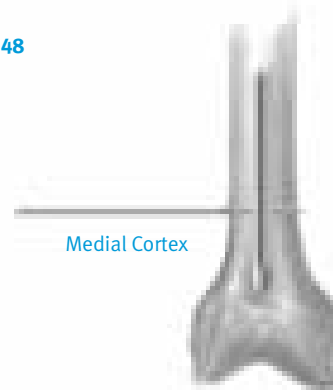

Fig. 49

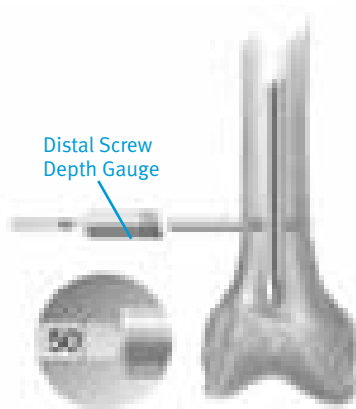

Fig. 50

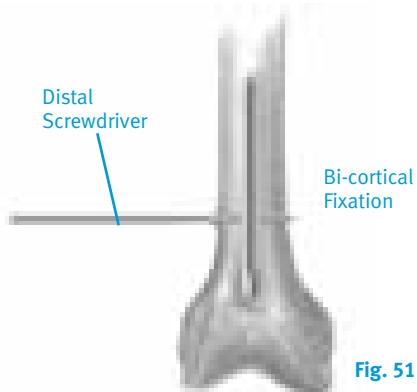

Fig. 51

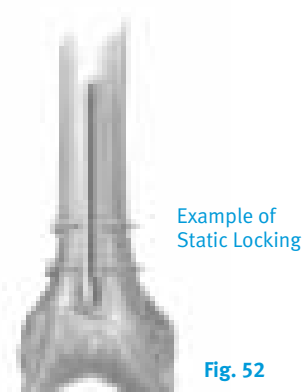

Fig. 52

Completion

Remove the *ITST* Barrel Targeting Arm, Threaded Driver and Locking Bolt using the Locking Bolt Extractor. Take care to leave the Lag Screw Inserter Link in place for final Nail Cap seating.

Insert the appropriate Nail Cap: Neutral Nail Cap (Fig. 53), Sliding Nail Cap (Fig. 54), or Locking Nail Cap (Fig. 55) with the Nail Cap Inserter (Fig. 57).

* All Nail Caps are available in 0, 5, 10, 15, and 20mm head sizes.

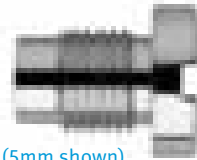

Fig. 53 Neutral Cap* (5mm shown)

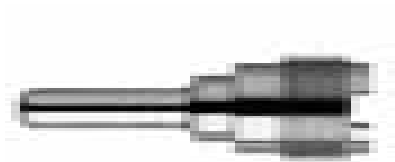
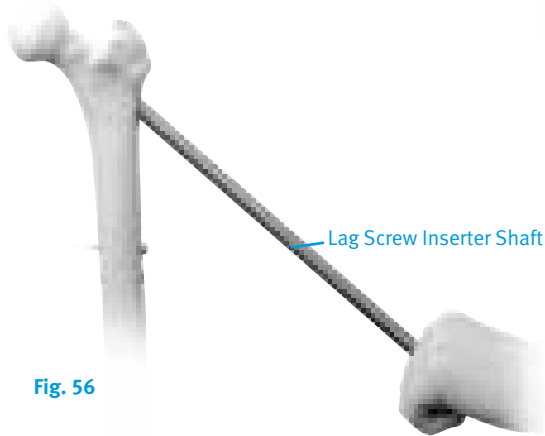

Fig. 54 Sliding Cap* (0mm shown)



Fig. 55 Locking Cap* (15mm shown)

Tighten until fully seated. If using a Sliding or Locking Cap, slide the Lag Screw Inserter Shaft over the Insert Link and into the Lag Screw (Fig. 57). Slowly rotate the Lag Screw Inserter and Nail Cap Inserter until the Nail Cap flange can be felt seating into one of the four lag screw shaft grooves (Fig. 56, 57).



Closure and Postoperative Care

Close the proximal wound and apply a soft compression dressing.

Postoperative range of motion exercises and weight bearing should be individually determined by the surgeon based on patient age, fracture pattern, and surgeon evaluation.

Extraction

In order to extract the nail, remove any existing distal screws with the 3.5mm T-Handle Hex Screwdriver. Remove the Nail Cap with the 5.0mm T-Handle Screwdriver. Make a small incision in the area of the existing proximal incision to expose the ends of the Lag Screw and Anti-Rotation Screw. Clear any bony ingrowth away from the Lag Screw hex, and thread the Retaining Shaft into the Lag Screw. Slide the Lag Screw Inserter into the Lag Screw, and tighten the Extraction Knob. Remove the lag screw, turning counter clockwise, with a slight backward pulling motion (Fig. 59). Once the Lag Screw has been removed, use the 5.0mm T-Handled Hexdriver to remove the Anti-Rotation Screw.

Attach the Extractor Bolt (00-2258-064-00) into the nail (Fig. 60). Screw the Slaphammer onto the Extractor Bolt and remove the nail.

Extraction instruments are not included in the Standard Set and must be procured separately.

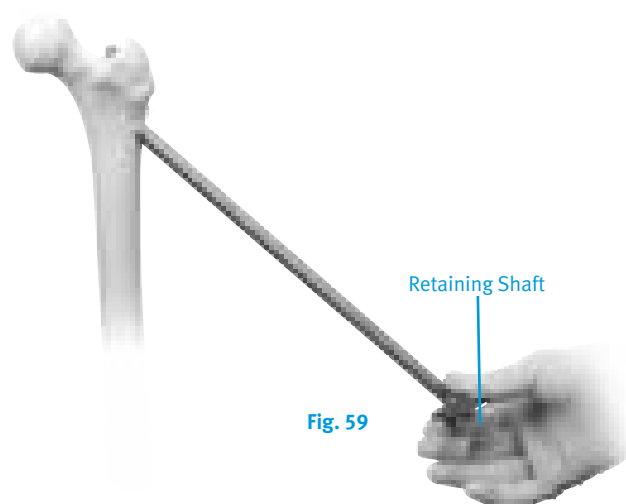

Fig. 59

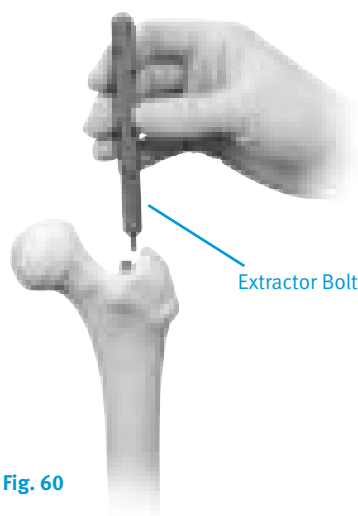

Fig. 60

Implant and Instrument Case Options

Prod. No.	Description	Size
00-2257-000-07	ITST Asia Set (contains the following)	
00-2256-180-10	Univ L/R Fem IM Nail	10mmDX18cm
00-2256-180-11	Univ L/R Fem IM Nail	11mmDX18cm
00-2256-180-12	Univ L/R Fem IM Nail	12mmDX18cm
00-2256-180-13	Univ L/R Fem IM Nail	13mmDX18cm
00-2256-180-14	Univ L/R Fem IM Nail	14mmDX18cm
00-2256-180-15	Univ L/R Fem IM Nail	15mmDX18cm
00-2257-000-05	ITST Global Short Set (contains the following)	
00-2257-180-10	Univ L/R Fem IM Nail	10mmDX18cm
00-2257-180-11	Univ L/R Fem IM Nail	11mmDX18cm
00-2257-180-12	Univ L/R Fem IM Nail	12mmDX18cm
00-2257-180-13	Univ L/R Fem IM Nail	13mmDX18cm
00-2257-180-14	Univ L/R Fem IM Nail	14mmDX18cm
00-2257-180-15	Univ L/R Fem IM Nail	15mmDX18cm
00-2257-000-06	ITST Global Long Set (contains the following)	
00-2257-300-00	Left Fem IM Nail	10mmDX30cm
00-2257-300-01	Left Fem IM Nail	11mmDX30cm
00-2257-300-02	Left Fem IM Nail	12mmDX30cm
00-2257-300-03	Left Fem IM Nail	13mmDX30cm
00-2257-300-04	Left Fem IM Nail	14mmDX30cm
00-2257-300-10	Right Fem IM Nail	10mmDX30cm
00-2257-300-11	Right Fem IM Nail	11mmDX30cm
00-2257-300-12	Right Fem IM Nail	12mmDX30cm
00-2257-300-13	Right Fem IM Nail	13mmDX30cm
00-2257-300-14	Right Fem IM Nail	14mmDX30cm
00-2257-320-00	Left Fem IM Nail	10mmDX32cm
00-2257-320-01	Left Fem IM Nail	11mmDX32cm
00-2257-320-02	Left Fem IM Nail	12mmDX32cm
00-2257-320-03	Left Fem IM Nail	13mmDX32cm
00-2257-320-04	Left Fem IM Nail	14mmDX32cm
00-2257-320-10	Right Fem IM Nail	10mmDX32cm
00-2257-320-11	Right Fem IM Nail	11mmDX32cm
00-2257-320-12	Right Fem IM Nail	12mmDX32cm
00-2257-320-13	Right Fem IM Nail	13mmDX32cm
00-2257-320-14	Right Fem IM Nail	14mmDX32cm
00-2257-340-00	Left Fem IM Nail	10mmDX34cm
00-2257-340-01	Left Fem IM Nail	11mmDX34cm
00-2257-340-02	Left Fem IM Nail	12mmDX34cm
00-2257-340-03	Left Fem IM Nail	13mmDX34cm
00-2257-340-04	Left Fem IM Nail	14mmDX34cm
00-2257-340-10	Right Fem IM Nail	10mmDX34cm
00-2257-340-11	Right Fem IM Nail	11mmDX34cm
00-2257-340-12	Right Fem IM Nail	12mmDX34cm
00-2257-340-13	Right Fem IM Nail	13mmDX34cm
00-2257-340-14	Right Fem IM Nail	14mmDX34cm
00-2257-360-00	Left Fem IM Nail	10mmDX36cm
00-2257-360-01	Left Fem IM Nail	11mmDX36cm
00-2257-360-02	Left Fem IM Nail	12mmDX36cm
00-2257-360-03	Left Fem IM Nail	13mmDX36cm
00-2257-360-04	Left Fem IM Nail	14mmDX36cm
00-2257-360-10	Right Fem IM Nail	10mmDX36cm
00-2257-360-11	Right Fem IM Nail	11mmDX36cm
00-2257-360-12	Right Fem IM Nail	12mmDX36cm
00-2257-360-13	Right Fem IM Nail	13mmDX36cm
00-2257-360-14	Right Fem IM Nail	14mmDX36cm
00-2257-380-00	Left Fem IM Nail	10mmDX38cm
00-2257-380-01	Left Fem IM Nail	11mmDX38cm
00-2257-380-02	Left Fem IM Nail	12mmDX38cm
00-2257-380-03	Left Fem IM Nail	13mmDX38cm
00-2257-380-04	Left Fem IM Nail	14mmDX38cm
00-2257-380-10	Right Fem IM Nail	10mmDX38cm
00-2257-380-11	Right Fem IM Nail	11mmDX38cm
00-2257-380-12	Right Fem IM Nail	12mmDX38cm
00-2257-380-13	Right Fem IM Nail	13mmDX38cm
00-2257-380-14	Right Fem IM Nail	14mmDX38cm
00-2257-400-00	Left Fem IM Nail	10mmDX40cm
00-2257-400-01	Left Fem IM Nail	11mmDX40cm
00-2257-400-02	Left Fem IM Nail	12mmDX40cm
00-2257-400-03	Left Fem IM Nail	13mmDX40cm
00-2257-400-04	Left Fem IM Nail	14mmDX40cm
00-2257-400-10	Right Fem IM Nail	10mmDX40cm
00-2257-400-11	Right Fem IM Nail	11mmDX40cm
00-2257-400-12	Right Fem IM Nail	12mmDX40cm
00-2257-400-13	Right Fem IM Nail	13mmDX40cm
00-2257-400-14	Right Fem IM Nail	14mmDX40cm
00-2257-420-00	Left Fem IM Nail	10mmDX42cm
00-2257-420-01	Left Fem IM Nail	11mmDX42cm
00-2257-420-02	Left Fem IM Nail	12mmDX42cm
00-2257-420-03	Left Fem IM Nail	13mmDX42cm
00-2257-420-04	Left Fem IM Nail	14mmDX42cm
00-2257-420-10	Right Fem IM Nail	10mmDX42cm

00-2257-420-11	Right Fem IM Nail	11mmDX42cm
00-2257-420-12	Right Fem IM Nail	12mmDX42cm
00-2257-420-13	Right Fem IM Nail	13mmDX42cm
00-2257-420-14	Right Fem IM Nail	14mmDX42cm
00-2257-440-00	Left Fem IM Nail	10mmDX44cm
00-2257-440-01	Left Fem IM Nail	11mmDX44cm
00-2257-440-02	Left Fem IM Nail	12mmDX44cm
00-2257-440-03	Left Fem IM Nail	13mmDX44cm
00-2257-440-04	Left Fem IM Nail	14mmDX44cm
00-2257-440-10	Right Fem IM Nail	10mmDX44cm
00-2257-440-11	Right Fem IM Nail	11mmDX44cm
00-2257-440-12	Right Fem IM Nail	12mmDX44cm
00-2257-440-13	Right Fem IM Nail	13mmDX44cm
00-2257-440-14	Right Fem IM Nail	14mmDX44cm
00-2257-460-00	Left Fem IM Nail	10mmDX46cm
00-2257-460-01	Left Fem IM Nail	11mmDX46cm
00-2257-460-02	Left Fem IM Nail	12mmDX46cm
00-2257-460-03	Left Fem IM Nail	13mmDX46cm
00-2257-460-04	Left Fem IM Nail	14mmDX46cm
00-2257-460-10	Right Fem IM Nail	10mmDX46cm
00-2257-460-11	Right Fem IM Nail	11mmDX46cm
00-2257-460-12	Right Fem IM Nail	12mmDX46cm
00-2257-460-13	Right Fem IM Nail	13mmDX46cm
00-2257-460-14	Right Fem IM Nail	14mmDX46cm
00-2257-480-00	Left Fem IM Nail	10mmDX48cm
00-2257-480-01	Left Fem IM Nail	11mmDX48cm
00-2257-480-02	Left Fem IM Nail	12mmDX48cm
00-2257-480-03	Left Fem IM Nail	13mmDX48cm
00-2257-480-04	Left Fem IM Nail	14mmDX48cm
00-2257-480-10	Right Fem IM Nail	10mmDX48cm
00-2257-480-11	Right Fem IM Nail	11mmDX48cm
00-2257-480-12	Right Fem IM Nail	12mmDX48cm
00-2257-480-13	Right Fem IM Nail	13mmDX48cm
00-2257-480-14	Right Fem IM Nail	14mmDX48cm
00-2257-500-00	Left Fem IM Nail	10mmDX50cm
00-2257-500-01	Left Fem IM Nail	11mmDX50cm
00-2257-500-02	Left Fem IM Nail	12mmDX50cm
00-2257-500-03	Left Fem IM Nail	13mmDX50cm
00-2257-500-04	Left Fem IM Nail	14mmDX50cm
00-2257-500-10	Right Fem IM Nail	10mmDX50cm
00-2257-500-11	Right Fem IM Nail	11mmDX50cm
00-2257-500-12	Right Fem IM Nail	12mmDX50cm
00-2257-500-13	Right Fem IM Nail	13mmDX50cm
00-2257-500-14	Right Fem IM Nail	14mmDX50cm
Nail Caps		
00-2259-007-00	ITST 1-Piece Slide Nail Cap	0mm
00-2259-007-05	ITST 1-Piece Slide Nail Cap	5mm
00-2259-007-10	ITST 1-Piece Slide Nail Cap	10mm
00-2259-007-15	ITST 1-Piece Slide Nail Cap	15mm
00-2259-007-20	ITST 1-Piece Slide Nail Cap	20mm
00-2259-008-00	ITST 1-Piece Lock Nail Cap	0mm
00-2259-008-05	ITST 1-Piece Lock Nail Cap	5mm
00-2259-008-10	ITST 1-Piece Lock Nail Cap	10mm
00-2259-008-15	ITST 1-Piece Lock Nail Cap	15mm
00-2259-008-20	ITST 1-Piece Lock Nail Cap	20mm
00-2259-009-00	ITST 1-Piece NTRL Nail Cap	0mm
00-2259-009-05	ITST 1-Piece NTRL Nail Cap	5mm
00-2259-009-10	ITST 1-Piece NTRL Nail Cap	10mm
00-2259-009-15	ITST 1-Piece NTRL Nail Cap	15mm
00-2259-009-20	ITST 1-Piece NTRL Nail Cap	20mm
00-2257-000-09	Anti-Rotation Screws (contains the following)	
00-2257-060-65	ITST Anti-Rotation Screw	6.5mmDX60mm
00-2257-065-65	ITST Anti-Rotation Screw	6.5mmDX65mm
00-2257-070-65	ITST Anti-Rotation Screw	6.5mmDX70mm
00-2257-075-65	ITST Anti-Rotation Screw	6.5mmDX75mm
00-2257-080-65	ITST Anti-Rotation Screw	6.5mmDX80mm
00-2257-085-65	ITST Anti-Rotation Screw	6.5mmDX85mm
00-2257-090-65	ITST Anti-Rotation Screw	6.5mmDX90mm
00-2257-095-65	ITST Anti-Rotation Screw	6.5mmDX95mm
00-2257-100-65	ITST Anti-Rotation Screw	6.5mmDX100mm
00-2257-105-65	ITST Anti-Rotation Screw	6.5mmDX105mm
00-2257-110-65	ITST Anti-Rotation Screw	6.5mmDX110mm
ITST Asia Lag Screws		
00-2256-002-27	Asia 1-Piece Lag Screw	11mmDX70mm
00-2256-002-30	Asia 1-Piece Lag Screw	11mmDX75mm
00-2256-002-32	Asia 1-Piece Lag Screw	11mmDX80mm
00-2256-002-35	Asia 1-Piece Lag Screw	11mmDX85mm
00-2256-002-37	Asia 1-Piece Lag Screw	11mmDX90mm
00-2256-002-40	Asia 1-Piece Lag Screw	11mmDX95mm
00-2256-002-42	Asia 1-Piece Lag Screw	11mmDX100mm
00-2256-002-45	Asia 1-Piece Lag Screw	11mmDX105mm
00-2256-002-47	Asia 1-Piece Lag Screw	11mmDX110mm
00-2256-002-50	Asia 1-Piece Lag Screw	11mmDX115mm
00-2256-002-52	Asia 1-Piece Lag Screw	11mmDX120mm

ITST Standard Lag Screws

00-2259-001-27	1-Piece Lag Screw	11mmDX70mm
00-2259-001-30	1-Piece Lag Screw	11mmDX75mm
00-2259-001-32	1-Piece Lag Screw	11mmDX80mm
00-2259-001-35	1-Piece Lag Screw	11mmDX85mm
00-2259-001-37	1-Piece Lag Screw	11mmDX90mm
00-2259-001-40	1-Piece Lag Screw	11mmDX95mm
00-2259-001-42	1-Piece Lag Screw	11mmDX100mm
00-2259-001-45	1-Piece Lag Screw	11mmDX105mm
00-2259-001-47	1-Piece Lag Screw	11mmDX110mm
00-2259-001-50	1-Piece Lag Screw	11mmDX115mm
00-2259-001-52	1-Piece Lag Screw	11mmDX120mm

00-2258-000-11 ITST Nail Instrument Set for use with Mod Targeting Guide

00-2258-007-00	<i>ITST</i> Short Nail Instrument Case Tray	
00-2258-008-00	<i>ITST</i> Instrument Case Lid	
00-2237-053-00	Wire Grip T-Handle	
00-2237-061-00	Cannulated Awl	
00-2255-028-00	9/16 in. Pin Wrench	
00-2255-038-00	T-Handle	
00-2258-051-01	Locking Bolt Extractor	
00-2258-051-02	Locking Bolt Inserter	
00-2258-090-00	<i>ITST</i> Cannula	
00-2258-091-00	<i>ITST</i> Centering Bushing	
00-2258-092-03	MIS Nail Cap Inserter Link	
00-2258-092-04	MIS Nail Cap Inserter	
00-2258-096-00	U-Joint Sleeve	
00-5791-049-00	Screw Inserter/Extractor	
00-2258-054-00	Threaded Guide Pin Bushing	
00-2258-056-00	Lag Screw Bushing	
00-2258-058-00	Lag Screw Reamer	
00-2258-059-00	Lag Screw Tap	
00-2258-062-00	Stop Assembly (Qty: 2)	
00-2258-068-32	<i>ITST</i> Pin Bushing 3.2mm	
00-2258-068-50	<i>ITST</i> Drill Bushing 5.0mm	
00-2258-068-80	<i>ITST</i> Screw Bushing 8.0mm (Qty: 2)	
00-2258-069-50	<i>ITST</i> Femoral Drill 5.0mm	
00-2258-097-00	<i>ITST</i> Lag Screw Compression Device	

00-2258-000-06 ITST Modular Targeting Guide Set (Standard and MIS Technique Options)

00-2258-052-03	<i>ITST</i> Standard Barrel	
00-2258-052-04	<i>ITST</i> MIS Barrel	
00-2258-052-05	<i>ITST</i> Targeting Arm	
00-2258-052-06	Targeting Arm Nut	
00-2258-052-09	Modular Connecting Bolt	
00-2258-087-00	<i>ITST</i> Standard Locking Bolt	

00-2258-087-01	<i>ITST</i> MIS Locking Bolt	
00-2258-053-01	Modular Targeting Guide Outrigger	
00-2255-060-01	8mm MIS Trochanteric Reamer	
00-2258-050-02	Long <i>ITST</i> Taper Reamer	
00-2258-067-01	Long 3.2mm Threaded Guide Pin	
00-2258-057-01	Long Cannulated Depth Gauge	
00-2258-006-50	<i>ITST</i> Short Nail Instrument Case Base	

00-2258-000-03 ITST Accessory Instrument Set (includes all of the following listed below)

00-2258-010-00	<i>ITST</i> Accessory Instrument Case	
00-2237-043-00	5.0mm T-Handle Screwdriver	
00-2237-062-00	Long Threaded Driver	
00-2237-064-00	Nail Length Gauge	
00-2255-015-01	Wand Insert	
00-2255-015-02	Wand Set Screw	
00-2255-015-03	Wand Handle	
00-2255-018-00	Distal Screw Depth Gauge (short)	
00-2255-033-37	3.7mm Distal Trocar Drill (Qty: 2)	
00-2255-033-50	5.0mm Distal Trocar Drill (Qty: 2)	
00-2255-034-00	Reduction Finger	
00-2258-068-37	<i>ITST</i> 3.7mm Drill Bushing	
00-2258-069-37	<i>ITST</i> 3.7mm Drill	
00-2258-071-45	<i>ITST</i> 4.5mm Screw Tap	
00-2258-072-00	<i>ITST</i> Screw Depth Gauge (long)	
00-2258-077-00	Driver Extension	
00-2258-078-00	Driver Extension Bolt (Qty: 1)	

Optional ITST Instrumentation

00-4816-060-00	Straight Ball Spike Pusher	
00-4817-011-00	Medium Bone Hook (Shoulder Hook)	
00-2258-092-00	<i>ITST</i> One-Piece Nail Cap Inserter	
00-2258-092-01	<i>ITST</i> Linked Nail Cap Inserter	
00-2258-097-00	<i>ITST</i> Lag Screw Compression Assembly (Note: 00-2258-097-00 includes: Compression Device T-Handle, Compressor, Compression Retainer.)	
00-2258-097-01	Compression Retainer (Replacement Part)	
00-2258-000-10	ITST Modular Targeting Guide Asia Set (set includes all instruments and case)	
00-2258-052-12	<i>ITST</i> Asia Barrel	
00-2258-052-13	<i>ITST</i> Asia Targeting Arm	
00-2258-052-06	Targeting Arm Nut	
00-2258-052-09	Modular Connecting Bolt	
00-2258-087-02	<i>ITST</i> Asia Locking Bolt	
00-2258-053-01	Modular Targeting Guide Outrigger	
00-2258-067-01	Long 3.2mm Threaded Guide Pin	
00-2258-057-01	Long Cannulated Depth Gauge	
00-2258-006-50	<i>ITST</i> Short Nail Instrument Case Base	

This documentation is intended exclusively for physicians and is not intended for laypersons. Information on the products and procedures contained in this document is of a general nature and does not represent and does not constitute medical advice or recommendations. Because this information does not purport to constitute any diagnostic or therapeutic statement with regard to any individual medical case, each patient must be examined and advised individually, and this document does not replace the need for such examination and/or advice in whole or in part. Please refer to the package inserts for important product information, including, but not limited to, contraindications, warnings, precautions, and adverse effects.



Contact your Zimmer representative or visit us at www.zimmer.com

The CE mark is valid only if it is also printed on the product label.

