



ZMR[®] Porous Revision Hip Prosthesis

Surgical Technique



Designed to Address the Unpredictable



ZMR Porous Revision Hip Prosthesis Surgical Technique

Table of Contents

Introduction	2
The Challenge	2
Design Goals	2
An Answer	2
Preoperative Planning	2
Bone Deficiency Classification	2
Objectives Of Preoperative Planning	4
Assessment Of Bone Loss And Component Selection	5
Determination Of Leg Length	5
Determination Of Femoral Offset And Abductor Muscle Tension	5
Templating For The ZMR Porous Revision Hip System	6
Determining The Type, Size, Build-up, And Offset Of The Modular Proximal Body	7
Determining The Modular Distal Stem Size And Length	8
Surgical Technique	10
Surgical Approach Factors	10
Determination Of Intraoperative Leg Length	14
Component Removal	15
Distal Canal Preparation	16
Proximal Femur Preparation	18
Trial Reduction	22
Implantation	25
Femoral Head Assembly	28
Wound Closure	28
Postoperative Management	29
Implant Removal	29

Introduction

The Challenge

In performing revision arthroplasty, the surgeon is challenged with a technically demanding procedure that requires creative resources from both the surgeon and the implant manufacturer. Although varying amounts of femoral bone loss may be encountered, reconstruction resulting in a stable femur/implant construct and restoration of joint kinematics are crucial for a successful outcome. In this unpredictable surgical environment, it is important that the instrumentation facilitates accomplishing these goals precisely and efficiently.

Design Goals

An Answer

In revision hip surgery, there are a number of implants and philosophies from which the surgeon can choose based on factors such as the amount and location of femoral bone loss, the quality of the remaining bone, and the age and activity level of the patient. The *ZMR Porous Revision Hip Prosthesis* can address a wide variety of situations, including some of the most demanding in femoral revision surgery.

With the mid-stem modular junction, the *ZMR Porous Revision Hip System* is designed to provide proximal or extensive (both proximal and distal) fixation. Various combinations of body and stem components offer many choices for fixation and restoration of joint kinematics. The proximal bodies also have varying build-up and offset options to help restore leg length and abductor muscle tensioning.

Preoperative Planning

Preoperative planning is of critical importance in femoral revision surgery. It helps determine the needs for removal of the existing implant, the amount of bone deficiency, and the type and approximate size of femoral implant required to reconstruct the femur. In revising a femoral component, the surgeon must decide on the best surgical approach and method of removing the femoral prosthesis that will provide adequate exposure while minimizing additional bone loss.

Bone Deficiency Classification

Preoperative x-ray analysis to determine the location and amount of femoral bone loss will assist the surgeon in assessing what type of femoral implants are appropriate, whether the approximate size of implant is available or if a special-order implant is needed. The analysis will also help determine whether any special accessories will be required such as allograft or cables. Support for the proximal body must be available or attainable above the mid-stem modular junction when implanting the *ZMR Porous Revision Prosthesis*.

There are a number of femoral bone defect classification systems using various methods with a range of complexity. The following classification system* is a modification of the AAOS classification system for femoral bone loss. It allows femoral bone loss to be placed in easy-to-recognize categories based on radiographic identification. This will assist the surgeon in preoperative planning and intraoperative reconstruction. The revision strategy may change significantly based on other factors or intraoperative findings.



Fig. 1

Type I Femoral Deficiency

- No significant bone loss

Type I femoral bone deficiencies are similar to a primary total hip with some minor bone defects. Type I deficiencies have the least amount of bone loss, and provide good bone for structural support and implant fixation (Fig. 1).



Fig. 2

Type II Femoral Deficiency

- **Contained** “ballooning” cavitory bone loss with thinning of cortices

Type II femoral bone deficiencies represent more bone loss in the proximal femur that is contained within thinning cortices. Type II deficiencies provide less proximal femoral structural support, particularly in controlling rotation (Fig. 2).

* Saleh KJ, Gross AF, Gafni A, et al. Radiographic classification for failed hip arthroplasty. 53rd Annual Meeting, Canadian Orthopaedic Association, June 1998, Ottawa, Ontario.



Fig. 3

Type III Femoral Deficiency

- Uncontained segmental bone loss less than 5cm in length, extending to, and including, the lesser trochanter

Type III femoral bone deficiencies are characterized by more extensive bone loss that is uncontained in the proximal femur. Segmental bone loss does not provide for resistance to axial or rotational forces (Fig. 3).



Fig. 4

Type IV Femoral Deficiency

- Uncontained segmental bone loss greater than 5cm in length, extending into the diaphysis

Type IV femoral bone deficiencies demonstrate severe proximal femoral bone loss with involvement of the diaphysis. There is no supportive proximal femoral bone and the diaphyseal structural support is compromised or minimal (Fig. 4).

Objectives of Preoperative Planning

The objectives of preoperative planning include:

1. Assess amount of bone loss to:
 - Select type(s) of implant(s) appropriate to reconstruct the femur.
 - Determine any special needs such as allograft or adjunctive fixation (cables, plates, etc.)
2. Ensure that the proximal body will be supported proximal to the mid-stem modular junction.
3. Obtain the anticipated component size necessary to provide structural stability.
4. Establish parameters of joint kinematic restoration that include:
 - Determination of leg length.
 - Restoration of offset for abductor muscle tensioning.
5. Assess the acetabulum to determine if any acetabular reconstruction is needed, and consider the potential impact of the acetabular reconstruction on the femoral side.

Assessment of Bone Loss and Component Selection

To select the appropriate type of implant in femoral revision surgery, a number of factors must be evaluated. Reconstructing the femur based on the amount of femoral bone loss and the status of the remaining bone is important in determining the appropriate prosthesis.

The *ZMR* Porous Revision Hip System is a versatile system that can address a wide range of femoral revision needs. It offers the surgeon multiple fixation options. These options include proximal fixation, and combined proximal and distal fixation (extensive fixation). The system is a logical choice for Type II and III femoral bone deficiencies, and can also be used with some Type I and some Type IV deficiencies. The implant choice will depend on the individual patient and the surgeon's fixation preference.

Important Note: Where there is loss of or insufficient femoral bone stock, bone grafting, or other adjunctive reinforcement procedures are advisable to provide proximal support to the body. This is necessary because, without proximal support, the mid-stem modular junction is vulnerable to fracture. In cases where proximal support cannot be achieved, an alternative surgical option should be considered.

Determination of Leg Length

Preoperative determination of leg length is essential for the restoration of the appropriate leg length during surgery. In femoral revision surgery, correction of leg length discrepancy is usually necessary because of bone and soft tissue changes resulting from the failed prosthesis.

An anterior/posterior (A/P) pelvic radiograph often provides enough detail of leg length inequality to proceed with surgery. If more information is needed, a full-length femoral x-ray view may be helpful. From the clinical examination and radiographic information on leg length, the needed correction, if any, can be determined.

If leg length is to be maintained or minimally increased, it is usually possible to perform the operation successfully without osteotomy of the greater trochanter, unless extensive exposure of the acetabulum or femur is necessary. However, if there is some major anatomic abnormality, osteotomy of the greater trochanter may be helpful and safer.

In the unusual situation where the limb is to be significantly shortened, subtrochanteric osteotomy, or osteotomy and advancement of the greater trochanter are mandatory. If the limb is shortened without one of these techniques, the abductors will be lax postoperatively, and the risk of dislocation will be high. Also, gait will be compromised by the laxity of the abductors.

Determination of Femoral Offset and Abductor Muscle Tension

After establishing the desired leg length requirements, abductor muscle tensioning through femoral offset must be considered. Restoring adductor tension places the abductor muscles at their optimal mechanical advantage, and results in improved functioning with less chance of dislocation and limp.

When the patient has a very large offset between the femoral head center of rotation and the line that bisects the medullary canal, the insertion of a femoral component with a lesser offset will, in effect, medialize the femoral shaft. To the extent that this occurs, laxity in the abductors will result.

Using the *ZMR* Porous Revision Templates on the preoperative x-ray film allows the surgeon to estimate the amount of offset needed for the new femoral component.

Templating for the ZMR Porous Revision Hip System

Preoperative planning for the insertion of the ZMR Porous Revision Femoral Component requires at least two views of the involved femur: an A/P view of the femur centered on the pubis symphysis, and a Lowenstein lateral view on an 11" x 17" cassette. Both views should show the full length of the femur. In addition, it may be helpful to obtain an A/P view of the involved side with the femur internally rotated. This compensates for naturally occurring femoral version, and provides a more accurate representation of the true medial-to-lateral dimension of the metaphysis.

When templating, magnification of the femur will vary depending on the distance from the x-ray source to the film, and the distance from the patient to the film. The ZMR Porous Revision Templates use 20 percent magnification, which is near the average magnification on most clinical x-rays. Large patients and obese patients may have magnification greater than 20 percent because osseous structures are farther away from the surface of the film. Likewise, smaller patients may have magnification less than 20 percent. If necessary, to better determine the magnification of any x-ray film, use a standardized marker at the level of the femur. (Templates of other magnification can be obtained as a special order by contacting your Zimmer Sales Representative.)

Preoperative planning is important in choosing the acetabular component if it is also being revised. Acetabular preoperative planning is beyond the scope of this document, but must be considered in conjunction with the use of the ZMR Porous Revision Femoral Prosthesis.

The objectives in templating the ZMR Porous Revision Femoral Component include:

1. Determining the type, size, position, length, and offset of the modular proximal body.
2. Choosing the type, size, length, and position of the distal stem.
3. Developing a plan for adjunctive support of the proximal body superior to the mid-stem modular junction.

The ZMR Porous Revision Templates include separate proximal body and distal stem templates. These templates are used together to help determine the final implant component.

To fit the Spout, Cone, and Calcar Bodies, separate templates are available for each of these ZMR body styles. Each body style is available in six sizes with incremental A/P and medial/lateral (M/L) dimensions.

The Spout Bodies are designed with a medial spout (curve) to provide fill for proximal fixation. These bodies are available in 35mm, 45mm, and 55mm (calcar) build-up heights with standard (40mm) and extended (46mm) offset options. The 40mm offset is only available in the 35mm body height.

The Cone Bodies, which are conical in shape, are designed for accurate fit at the metaphyseal/ diaphyseal junction. They provide a wide range of version adjustments. There are two build-up heights (45mm and 55mm) with only the extended (46mm) offset.

The Calcar Bodies are conical in shape. They have a collar that is designed to rest on the medial area of the femur for accurate fit at the metaphyseal/ diaphyseal junction. These bodies are available in two build-up heights (45mm and 55mm) with the extended (46mm) offset.

The build-up heights available with these proximal bodies, combined with femoral head-neck length options in 22mm, 26mm, 28mm, and 32mm diameters, help restore leg length. In addition, the body offset options, in combination with the modular femoral heads, assist in adjusting lateral offset and abductor muscle tensioning.

Another way to restore or compensate for offset is osteotomy and advancement of the greater trochanter to increase tension in the abductor muscles. In addition, the use of special acetabular liners can change the placement of the joint center of rotation.

The distal stem templates for the ZMR Porous Revision Hip Components include splined and fully porous coated options. The polished, splined distal stems provide distal augmentation to control rotational forces. The porous Splined Stem should be used if there is good potential for bone ingrowth on the proximal body in the young patient who is likely to have another revision during his lifetime. The porous-coated distal stems provide distal fill for axial and rotational control with porous coating for implant/bone fixation.

The distal stem templates show the modular junction level as well as the various stem lengths and diameters. The templates also indicate those stem sizes that have both straight and bowed options. The diameter measurements on the splined stem templates include the height of the splines. The diameter measurements of the porous stem templates are the approximate measurements taken over the porous coating.

Determining the Type, Size, Build-up, and Offset of the Modular Proximal Body

The modular proximal porous femoral body should be templated first. This allows the selected proximal body to determine where the mid-stem modular junction level will be prior to templating the distal stem component.

Selection of the proximal body type is determined in part by the femoral bone deficiency as assessed on the A/P radiograph. When the femoral tube is intact, the Spout Body can be used if proximal fill is desired. However, the Cone Body can also be used, particularly if special consideration must be given to version. When there is medial segmental femoral bone loss, either the Calcar Body or the Cone Body can be used.

Important Note: Since the ZMR Porous Revision Prosthesis may be used for the more difficult Type II through Type IV deficiencies, providing proximal support above the mid-stem modular junction is imperative. This can be achieved through bone grafting procedures such as impaction grafting, the use of cortical strut allografts, or other adjunctive reinforcement procedures.¹⁻³ Use of the ZMR XL should also be considered. It is important that the prosthesis not be distally fixed without proximal support.

Each porous body is available in six sizes that increase progressively in the A/P and M/L dimensions. Both A/P and lateral radiographs are essential in determining the appropriate sized implant. Lay the selected proximal body template over the A/P x-ray film to determine the fit (Fig. 5). Tight apposition of the implant to bone at the metaphyseal/diaphyseal junction

is important with all the proximal bodies; however, it is especially crucial with the Cone and Calcar Bodies because they rely on the flare of the distal portion of the proximal body to provide stability against axial load. Use the lateral radiograph to further assess the fit of the proximal body (Fig. 6).



Fig. 5

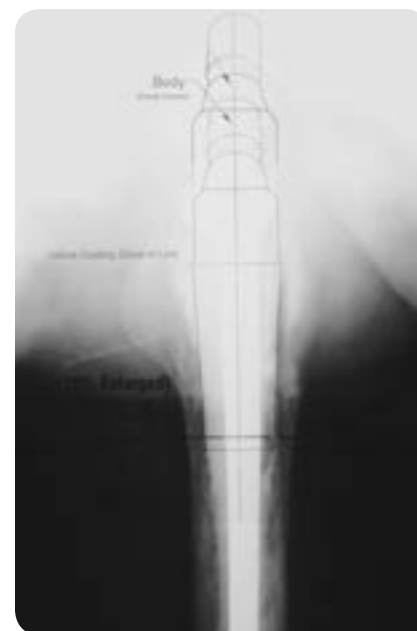

Fig. 6

The A/P x-ray view is useful in determining the correct leg length and offset needed for the reconstruction. The various build-up options (35mm, 45mm, 55mm) available with the modular bodies and femoral heads will allow for adjustment of leg length. The Spout Bodies are available with standard (40mm) and extended (46mm) offsets. The 40mm offset is available only in the 35mm body height. The extended offset bodies offer lateral translation of 6mm. This allows for an offset increase of 6mm without changing the vertical height or leg length. The femoral head lengths will also affect leg length and offset (Table 1).

Determining the Modular Distal Stem Size and Length

Use the distal stem templates in conjunction with the selected proximal body template to estimate the appropriate size and length of the distal stem. With the proximal body template still in position on the A/P x-ray film, or marked through the template holes, superimpose the distal stem template on the isthmus, making sure it aligns with the +0mm red line on the proximal body template. This will correctly align the mid-stem modular junction of the proximal body and distal stem.

Table 1: Adjustments available with the implant for restoring joint kinematics

Adjustments	Body	Head
Offset	Using standard and extended offset bodies will change offset only (6mm).	Using varying head lengths will change both offset and leg length (up to 10mm in 2.5mm increments). [†]
Leg Length	Using 35mm, 45mm, and 55mm body heights will change leg length only (up to 20mm in 10mm increments).	Using varying head lengths will change both leg length and offset (up to 10mm in 2.5mm increments).
Version	Adjustment is possible by rotating body on the stem for Calcar and Cone Body options.	No adjustment is possible.

[†] Using VerSys® Hip System 12/14 cobalt chrome heads

Estimate the size and length of the distal stem (Fig. 7). The distal stem should fill, or nearly fill, the medullary canal in the isthmus area on the A/P x-ray view. To provide for adequate stability, the stem length should be sufficient to engage at least 50mm of intact diaphyseal bone.

Next, overlay the proximal body and distal stem templates on the lateral radiograph to assess fill and appropriate stem length while taking the anterior bow of the femur into consideration (Fig. 8). Again, it is important that the distal stem template be aligned correctly with the +0mm red line on the proximal body template. In a femur with a pronounced anterior bow, the bowed stem should be considered. Another option is to use a shorter straight stem if there is adequate femoral canal engagement. The Spline Stems have a coronal slot, which facilitates insertion of a longer straight stem.

It is also important to have adequate stem length when bypassing any femoral defects. When bypassing a cortical defect, the implant should extend past the defect by a minimum of two and one-half times the measured canal diameter to provide adequate support.

Note: If templating shows use of a 16.5mm distal stem is possible, the ZMR XL should be considered.

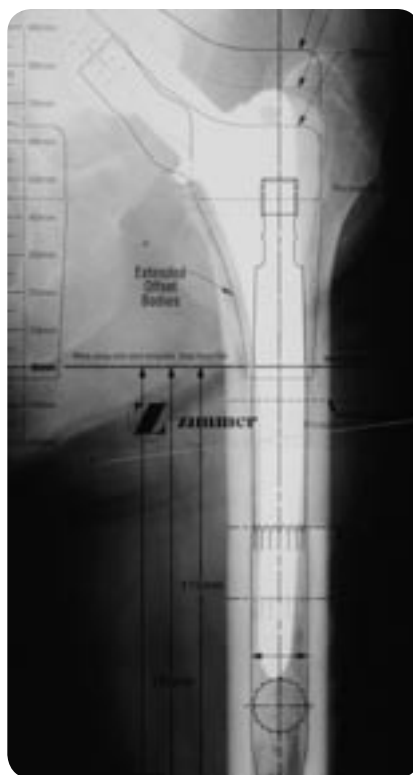

Fig. 7

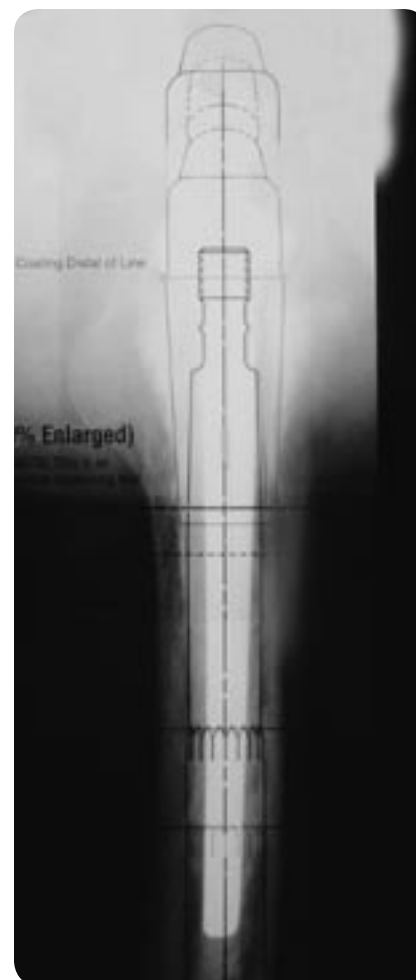

Fig. 8

Surgical Technique

Surgical Approach Factors

When determining which surgical approach is appropriate for a specific revision patient, a number of factors must be considered. The two most important factors are: 1) the difficulty of component removal, and 2) the complexity of the reconstruction. Other considerations include prior approaches and leg length discrepancy.

There are advantages and disadvantages with all approaches used in hip surgery. It is important that the surgeon be proficient with several different approaches to individualize the approach to patient needs.

A direct lateral (transgluteal)⁴ or anterolateral approach may be used when component removal is straight forward and reconstruction is not complex. The posterior approach⁵ provides better exposure for more difficult revisions, and it can easily be converted into a trochanteric osteotomy.

A transverse trochanteric osteotomy provides the best pelvic exposure, and very good femoral exposure, but there is a high incidence of trochanteric nonunion and escape.^{6,7}

A trochanteric slide provides better femoral exposure and, because the abductors and the vasti remain attached to the trochanter as a sling, there is less risk of trochanteric escape. If more pelvic exposure is required, a trochanteric slide can be converted to a transverse osteotomy by releasing the vasti.^{7,8,9}

The extended trochanteric osteotomy provides the best femoral exposure and may be used when difficulty in removing the femoral component is anticipated.^{7,9,10,11} The extended osteotomy and the slide also provide adequate pelvic exposure for complex acetabular reconstruction, but neither provides as much pelvic exposure as the transverse trochanteric osteotomy which provides the best access to the ilium and the anterior and posterior columns.

Removal of a protruded acetabular cup is difficult. Use extreme caution if the cup is adjacent to pelvic vessels or viscera. Preoperative angiography, CT, or IVP may be required, and a transtrochanteric approach is usually necessary. On the femoral side, cemented long stem or porous-coated long stems are the most difficult to remove. To facilitate removal of these components, a trochanteric osteotomy may be performed.

If a complex acetabular reconstruction is necessary because of loss of bone stock, the exposure should extend from the ilium to the ischium. This may require a posterior approach, and may also require a trochanteric osteotomy. Likewise, a complex femoral reconstruction may be accomplished more easily and without risk of fracture if a trochanteric approach is used.

If the leg must be lengthened more than 3cm, a trochanteric osteotomy will facilitate the procedure. If difficulty in reattachment is anticipated, then a trochanteric slide or an extended trochanteric osteotomy may be used. A subtrochanteric shortening osteotomy is also often advantageous.

Posterior Approach

Use a posterior approach as part of the trochanteric slide or the extended trochanteric osteotomy. It can also be used for a transverse osteotomy, although this is more commonly accomplished through a lateral approach. Make the skin incision parallel to the femoral shaft to just proximal to the tip of the greater trochanteric. Then curve the incision posteriorly toward the posterior iliac spine. Incise the fascia lata to expose the greater trochanter, abductors, and vastus lateralis. In some complex cases, it is necessary to expose the anterior capsule directly. To do this, place the hip in abduction and external rotation, identify the anterior boarder of the gluteus medius and retract it posteriorly. Perform an anterior capsulectomy. Identify the interval between the gluteus minimus and gluteus medius. Then place the hip in internal rotation and flexion.

Retract the posterior borders of the gluteus medius and gluteus minimus anteriorly, and identify the external rotators. The silver-white tendon of the piriformis forms the most superior part of the external rotators and serves as a landmark. Detach a flap from the greater trochanter. This flap should consist of the external rotators, beginning at the piriformis and extending distally to the quadratus femoris. The flap may also include the quadratus femoris. Mark the flap with a suture for later repair.

Perform a posteriorcapsulectomy and dislocate the hip posteriorly. This may be enough exposure but, if more is required, proceed to either a trochanteric slide or an extended trochanteric osteotomy. If more extensive posterior exposure is required, incise the proximal part of the gluteus maximus tendon and mark it with a suture for later repair. The sciatic nerve can be identified at this point and is thereafter protected by the flap of external rotators.

Trochanteric Slide and Extended Trochanteric Osteotomy

Both the trochanteric slide and the extended osteotomy involve developing the interval between the vastus lateralis and the posterior septum. Reflect the vastus lateralis anteriorly, but it should remain attached to the vastus lateralis ridge in continuity with the greater trochanter. This anterior reflection should not exceed one centimeter as it is important to leave the proximal fragment vascularized.

Trochanteric Slide

For the trochanteric slide, use an oscillating saw or osteotome to perform the osteotomy from posterior to anterior in the sagittal plane. The osteotomy cut should exit just distal to the vastus lateralis ridge. This will leave the trochanteric fragment enclosed in a sling of muscle consisting of the abductors proximally and the vastus lateralis distally (Figs. 9 & 10). This allows for stable reattachment and decreases the potential for trochanteric escape.



Fig. 9



Fig. 10

If desired, the trochanteric fragment can be made thick to include the gluteus medius and minimus. To accomplish this, angle the osteotomy anteromedially. Alternatively, the osteotomy can include the gluteus medius only, leaving the gluteus minimus attached to the femur. This will create a thinner fragment. Then, after making the osteotomy cut, dissect the gluteus minimus off the femur. It can be repaired later along with the external rotators. Having the gluteus minimus detached from the trochanteric fragment allows easier and more stable reattachment of the trochanteric fragment. If left attached to the trochanteric fragment, the gluteus minimus tethers the fragment anteriorly.

Retract the trochanteric fragment and its attached muscles anteriorly. Then use a large self-retaining retractor to dislocate the hip posteriorly in adduction and internal rotation.

To reattach the greater trochanter, use two cerclage wires through the lesser trochanter, or through the medial femoral cortex and the greater trochanter. If the trochanter is fragile, place the wires around the trochanter rather than through the drill holes. Then repair the external rotators and the gluteus minimus, and suture the vastus lateralis back to the septum (Figs. 11 & 12).

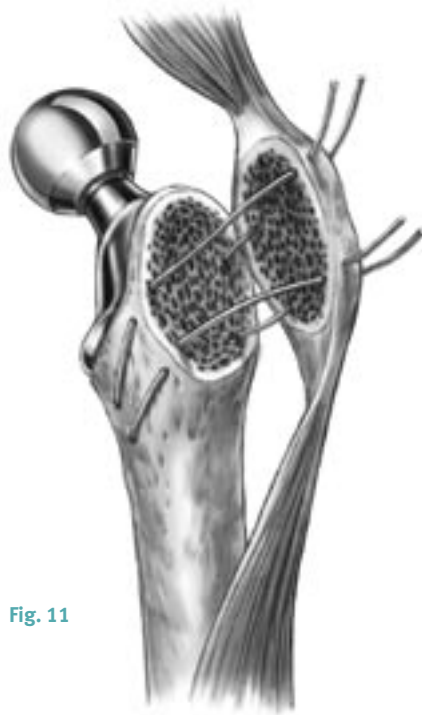

Fig. 11



Fig. 12

Extended Trochanteric Osteotomy

For an extended trochanteric osteotomy, the osteotomized fragment is much thicker, includes the entire trochanter, and extends into the diaphysis. The fragment includes the insertion of the gluteus medius and gluteus minimus, and involves approximately one-third of the diameter of the femur. The distal extent of the osteotomy depends on the length and fixation of the component to be removed and is determined from preoperative templating. The osteotomy should not extend into the metaphysis, or stem fixation may be difficult to achieve. It is optimal to retain at least 5cm of diaphyseal femur beyond the osteotomy.

Because the osteotomy involves one-third of the circumference of the femur, it is more easily performed after the hip has been dislocated and the femoral component removed. Typically, however, this is not possible because this approach is often being done to facilitate implant removal. In addition, if dislocation is difficult, the osteotomy should be done first.

Use the posterior approach and reflect the vastus lateralis off the septum, being careful to identify and cauterize perforating vessels. Limit the anterior reflection of the vasti muscles off the septum to about 1cm, or just enough to allow access for an oscillating saw or a high-speed burr. It is important to keep the muscle and the blood supply it brings attached to the long bony fragment.

With the hip in slight internal rotation, use an oscillating saw to perform the posterior limb of the osteotomy. Proximally, angle the saw blade medially to include all of the greater trochanter. Continue the cut distally on the posterolateral femur, just anterior to the linea aspera. The osteotomy should not exceed one-third the diameter of the proximal femur if the femoral component is still in place. Keep the distal horizontal end of the osteotomy rounded. If the femoral implant is small, it may be possible to make both the posterior and anterior cuts by passing the blade from posterior to anterior across the canal.

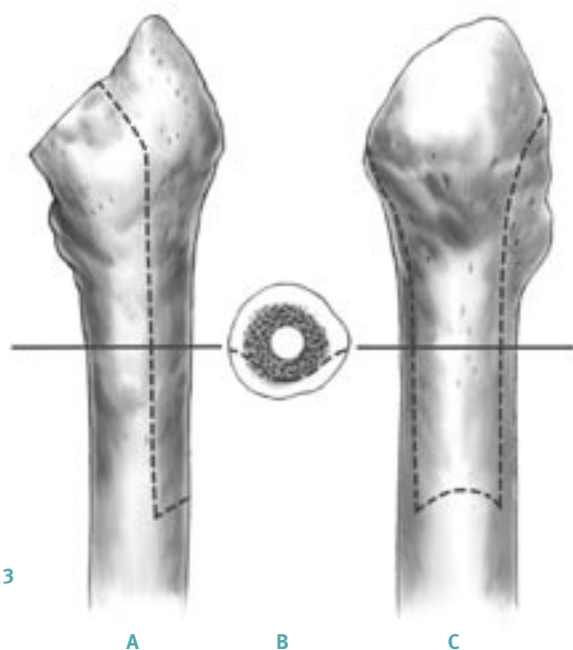

Fig. 13

If this is not possible, then use a narrow osteotome to weaken the anterior cortex after the posterior cut is made. Make multiple perforations through the muscle anteriorly without stripping it. This will keep the vastus lateralis attached, and the fragment vascularized. To avoid fracturing the greater trochanter, release the capsule anteriorly before levering the osteotomy open. Then, use multiple osteotomes to gently pry the osteotomy open from posterior to anterior, keeping the vastus lateralis attached. Retract the fragment anteriorly and remove the prosthesis (Figs. 13 & 14).

A long, porous-coated implant may still be quite solid after the osteotomy has been completed because of bony ingrowth on the medial side. This can be broken down with thin osteotomes or with a Gigli saw. If the distal part of the implant has not been exposed by the osteotomy then it may be necessary to section the implant at the distal aspect of the osteotomy and use a trephine to remove the distal stem.



Fig. 14

For cementless reconstruction, use a burr to shape the osteotomy fragment to fit the new prosthesis before reattachment. For cemented reconstruction, reattach the fragment before cementing. Use multiple (usually three or four) double-looped cerclage wires or cables (Fig. 15). Apply any available bone graft to the posterior osteotomy and suture the vastus lateralis back to the septum. If the osteotomy is not stable, use a cortical strut allograft to reinforce it. Abductor laxity can be addressed by shortening the osteotomy fragment and advancing it (Figs. 16 & 17). When testing range of motion, be careful to avoid anterior impingement of the osteotomized fragment.

Determination of Intraoperative Leg Length

Establish landmarks and obtain measurements before dislocation of the hip so that, after reconstruction, a comparison of leg length and femoral shaft offset can be obtained. From this comparison, adjustments can be made to achieve the goals established during preoperative planning.

There are several methods to measure leg length. Use the *Zimmer*® Joint Ruler, or a device/method that is most familiar. Take baseline measurements, then compare adjustments made intraoperatively to the preoperative plan. It is very important to use a reliable method of leg length assessment, particularly in femoral revision surgery, due to the changes in the joint that must be altered.



Fig. 15

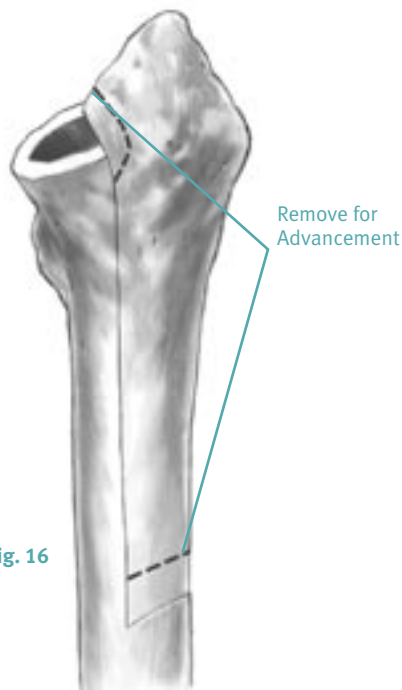

Fig. 16



Fig. 17

Component Removal

At times, various types of trochanteric osteotomies can facilitate femoral component removal. Removal of a well-fixed cemented component is a challenge for any surgeon. It is difficult to extract the implant from the femur while minimizing the risk of fracture and loss of existing bone stock. Avoiding perforation of the femur while removing the old bone cement is also a challenge. Removing a polished or smooth cemented femoral prosthesis is typically easier than removing a device that has a roughened surface. The use of thin osteotomes proximally helps remove overgrown bone and loosen the bone cement. If the component is difficult to extract, it is helpful to remove as much cement as possible laterally to help minimize the chance of fracturing the trochanter.

Once a cemented femoral component is extracted, completely remove the remaining bone cement from the femur. Remove the cement from proximal to distal, including the distal cement plug, if present. This can be accomplished with hand instruments, ultrasound systems, or any other suitable cement removal instruments. In difficult cases, an extended trochanteric osteotomy will provide excellent visualization and access for complete cement removal.

To remove a proximally porous-coated femoral implant, disrupt the proximal implant/bone interface and extract the stem using the extraction hole or by securing the taper as mentioned previously. A trochanteric osteotomy may facilitate removal of a well-fixed and ingrown proximal porous device. Use high-speed power tools or a Gigli saw to loosen the areas of bone ingrowth anteriorly, posteriorly, and medially.

Removal of an extensively porous coated femoral prosthesis is a more difficult task. An extended trochanteric osteotomy is frequently required. Disrupt the proximal fixation as described above. At times, the implant must be cut at the junction of the proximal body flare and the cylindrical distal stem with a high-speed metal-cutting instrument. After removing the proximal portion of the implant, use a trephine to ream over the top of the distal portion of the stem to break the interface between the implant and bone.

Surgical Technique Steps

1	Distal Canal Preparation	20
	A Straight Stems	21
	B Bowed Stems.	22
2	Proximal Femur Preparation	23
3	Trial Reduction	29
4	Implantation.	32
	A Back Table Assembly	32
	B Loose Assembly Technique	35

1 — Distal Canal Preparation

The distal femoral canal must be prepared to accept the distal femoral stem for either adjunct fixation (splined) or distal fixation (porous). The Spline Stems, when used in conjunction with the Spout Body, provide for distal adjunct stability, particularly rotational stability. This facilitates the proximal fixation of the Spout Body. The Porous Stems provide for distal fixation that can be used with any of the proximal bodies for an extensive fixation option.

Note: The ZMR Porous Revision Prosthesis is not intended to be used with distal fixation alone. The proximal body must be supported superior to the mid-stem modular junction.

A — Straight Stem Femoral Canal Preparation

When preparing the distal femoral canal for a straight distal stem component, use the straight intramedullary reamers (Fig. 18). Another option is to use the T-handle with the straight reamers for hand reaming. It is important to ream to the proper depth to assure adequate seating of the implant. The reaming depth should be greater than the preoperatively planned length. This will accommodate any change to the planned components.

Begin reaming with a straight reamer that is 4mm or 5mm smaller than the anticipated prosthesis size. Sequentially increase the reamer size by 0.5mm increments, making sure that each reamer is fully advanced to its appropriate depth and centered in the medullary canal. The appropriate reamer depth should be determined preoperatively when assessing the length of implant required. However, to accommodate any possible changes to the planned components, the reaming depth should be greater than the preoperatively planned length. The *VerSys* IM Reamer depth markings **DO NOT** directly correspond to the *ZMR* stem length options. Avoid varus positioning of the reamers. If the greater trochanter or lateral neck tends to push the reamer medially, use a small conical reamer (trochanteric router) to clear the obstruction and then resume the straight distal reaming. Ream until adequate cortical contact has been achieved. When using the Spline Stem option, underreaming of the canal by 0.5mm less than the implant (e.g., ream to 14.5mm to implant a size 15mm distal stem) will provide for additional apposition of the distal splines with the femoral canal.

The Spline Stem can be reamed line-to-line based on surgeon preference.

If a straight porous stem is chosen to provide axial stability, the canal should be underreamed by 0.5mm or reamed line-to-line. It is good practice to measure the diameter of the last reamer and compare it to the diameter of the actual prosthesis. Use an accurately calibrated caliper to perform this task.

Ultimately, the reaming decision is based on the patient's anatomy, length of stem, bone quality, and the surgeon's judgment and experience.



Fig. 18

B — Bowed Stem

Femoral Canal Preparation

When preparing the femoral canal to accept a bowed stem, flexible reamers must be used because they more closely follow the natural bow of the femur. The *Pressure Sentinel*® Intramedullary Reaming System has flexible reamers that result in lower intramedullary pressure levels and lower temperature levels that are at or below those of competitive systems.¹²

Warning: Tactile feedback with these flexible reamers may be different than straight reamers. Fluoroscopy can be used, if desired, to monitor the reaming process.

Insert a ball-tipped guide wire into the canal, and begin reaming 2mm or 3mm below the anticipated implant size (Fig. 19). Sequentially increase the reamer size by 0.5mm increments, making sure the reamer is fully advanced by passing through the femoral diaphysis. Ream until the desired canal diameter has been achieved. When reaming for the bowed Spline Stem, line-to-line to 1.0mm overreaming techniques can be used, depending on the patient's anatomy, bone quality, and surgeon judgment. The Spline Stem has a distal coronal slot design that makes the distal stem more flexible to accommodate the bow of the femur. When reaming for the bowed Porous Stem, it may be necessary to overream by as much as 1.0mm to accommodate the bow of the femur. In revision surgery, where the primary axial stability is achieved distally with an extensively porous coated stem, it may be necessary to ream line-to-line or overream 0.5mm to achieve this goal. The bowed Porous Stems do not have a coronal slot and are not as accommodating to the bow of the femur as slotted stems. Therefore, overreaming will facilitate the insertion of these stems.

Fig. 19



2 — Proximal Femur Preparation

Bone must be cleared from the proximal femur to allow for intimate apposition of the proximal body with bone. Regardless of which body style is used, proper preparation of the body conical region helps secure the body at the femoral metaphyseal/diaphyseal junction and provides resistance to axial load. When using the Spout Body, additional bone must be removed from the medial calcar region of the femur to match the spout geometry. The Spout Body is designed for use when medial fill in the metaphysis is desired.

When preparing for a Calcar Body, use the Osteotomy Guide as a reference when determining the level of cut for the selected Calcar Body. The Osteotomy Guide has two notches that align with the level of the 45mm and 55mm Calcar Body build-up lengths. These notches are referenced off the tip of the greater trochanter. The guide also has markings to align the +0mm head center with each body build-up height. These markings are also referenced off the tip of the greater trochanter (Fig. 20).

The Cone and Calcar Bodies are designed for use when defects extend below the lesser trochanter or proximal bone stock is of poor quality. The varied body heights allow the prosthesis to be deeply seated into the canal so it can be anchored in viable bone stock.

Note: Proximal bone support should be maintained. If femoral preparation has removed bone that would have provided proximal support, bone grafting or other adjunctive reinforcement procedures will be necessary.

To prepare the proximal femur for the conical portion of any proximal body style, choose a Distal Pilot that matches the size of the distal implant that will be used. For example, if the distal femoral canal was prepared for a 15mm distal stem, select the size 15 Distal Pilot. The Distal Pilot diameter is 14.3mm, or 0.7mm smaller than the implant diameter to allow for clearance down the canal while maintaining a secure fit. If, however, the diaphysis is overreamed (e.g., for a bowed stem), choose a Distal Pilot that more closely matches the final reamed size as the pilot is used to help center the Porous Body Conical Reamer.

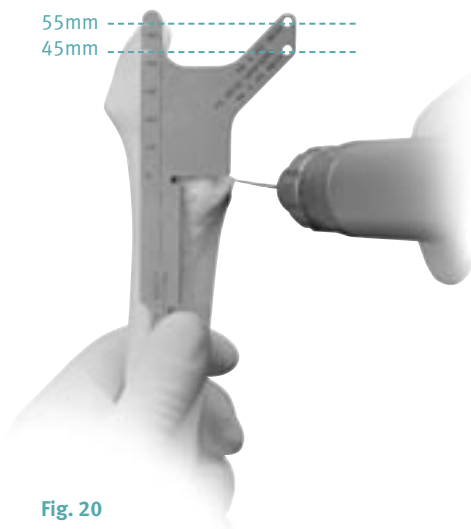

Fig. 20

Thread the **proper** Distal Pilot onto a Porous Body Conical Reamer that is 1 or 2 sizes below the anticipated body size and tighten it with the Distal Pilot Wrench (Fig. 21). The instrument tray contains three of each size Distal Pilot so they can be attached in advance to incrementally sized Porous Body Conical Reamers. Sequentially ream to the desired size proximal body and appropriate depth (Fig. 22).

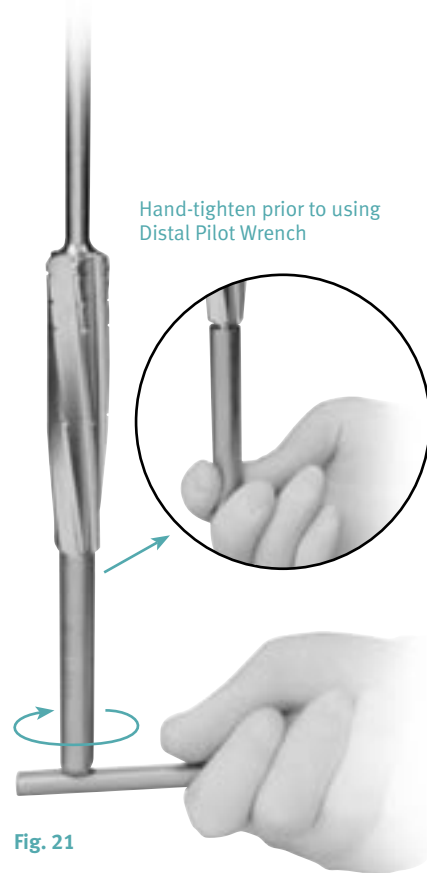

Fig. 21

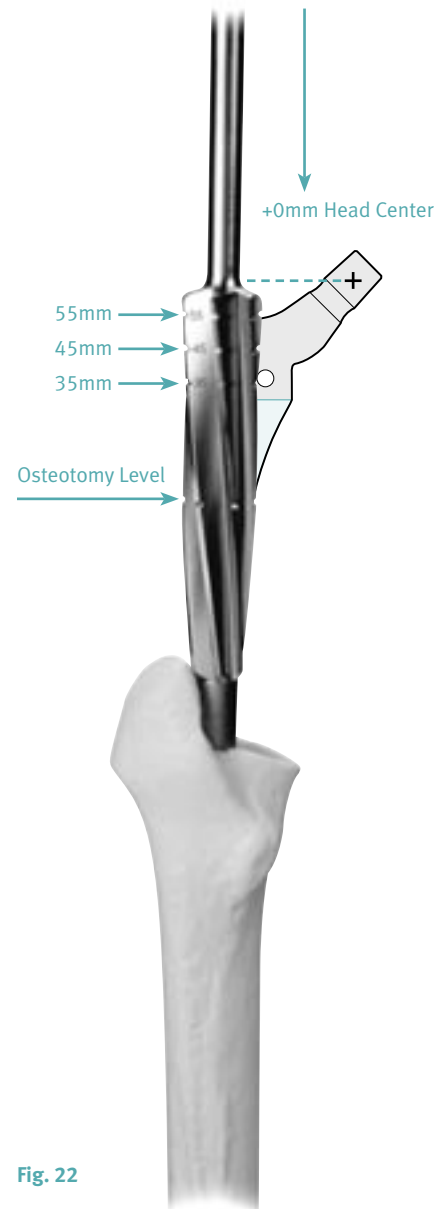

Fig. 22

Apply lateral and slight posterior pressure on the reamer to help maintain a centered orientation when reaming. The three most proximal marks on the Porous Body Conical Reamer match the 35mm, 45mm, and 55mm body build-up heights of the implants and are referenced off the tip of the greater trochanter (Fig. 23). If using a Calcar Body, advance the Porous Body Conical Reamer only to the most distal line on the reamer. This line should be referenced to the level of the osteotomy (Fig. 23a). These body lengths are referenced off the +0mm femoral head center.

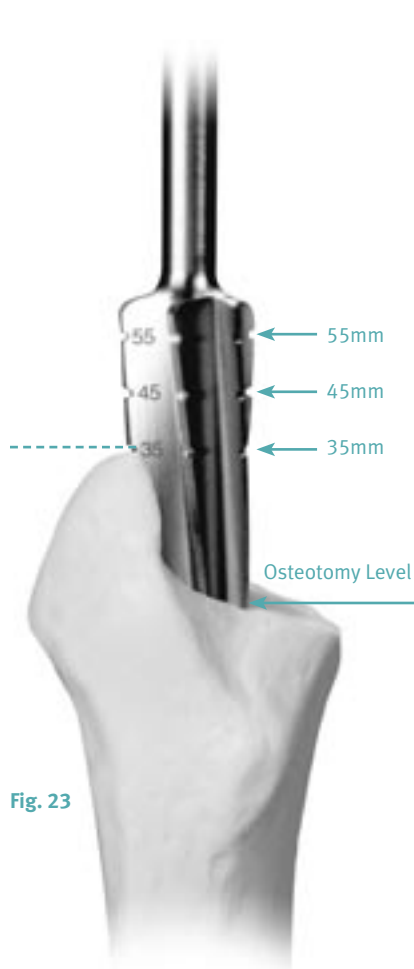

Fig. 23

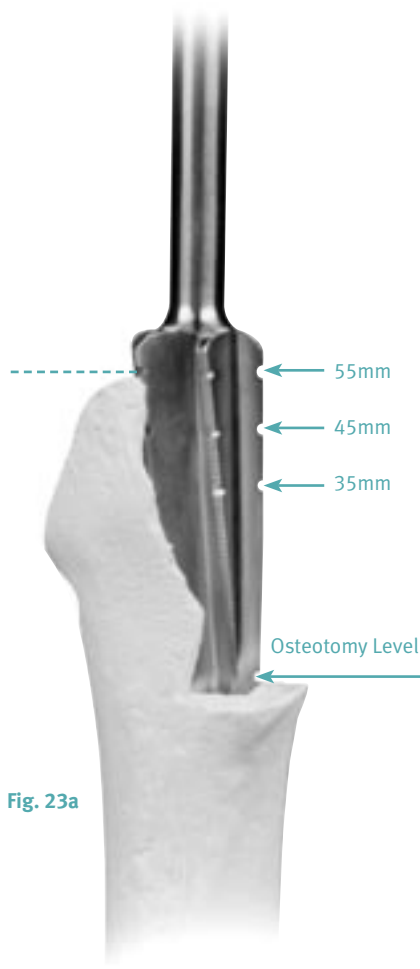

Fig. 23a

To help avoid disassociation of the Distal Pilot from the reamer, do not run the Porous Body Conical Reamer in reverse. (If the reamer is used in reverse and the Distal Pilot disassociates from the reamer, use the threaded end of the Distal Pilot Wrench to retrieve the Distal Pilot.) To facilitate removal of the Distal Pilot from the Porous Body Conical Reamer, attach the T-handle to the reamer and loosen with the Distal Pilot Wrench. If using the Cone or Calcar Body, preparation of the proximal femur is now complete.

If using the Spout Body, preparation of the medial calcar area must be completed. Select the appropriate Distal Pilot and thread it onto the appropriate size Spout Mill Guide (Fig. 24). Tighten it with the Distal Pilot Wrench. The final Porous Body Conical Reamer used will dictate which Spout Mill Guide to select and the final Distal Reamer size used will dictate the appropriate Distal Pilot (Table 2).

Table 2: Selection of Spout Mill Components

Conical Reamer Selected	Spout Mill Assembly	
	Spout Mill Guide Required	Spout Mill Cutter Required
A	A	A-B
B	B	A-B
C	C	C-D
D	D	C-D
E	E	E-F
F	F	E-F



Fig. 24

Pass the Spout Mill Guide/Distal Pilot assembly down the femoral canal to the appropriate level using the markings on the lateral side of the guide. The lines on the Spout Mill Guide match the 35mm, 45mm, and 55mm body heights and align with the top of the greater trochanter (Fig. 25). Insert the Spout Mill Guide to the same depth as the last Porous Body Conical Reamer used. For example, if the reamer reached the 45mm depth mark, then the 45mm depth mark on the Spout Mill Guide should be aligned with the top of the greater trochanter. The assembly should seat without force. Use the Stem Impactor to control rotation of the Spout Mill Guide during insertion. This will determine the final anteversion of the femoral prosthesis.

Attach the Spout Mill Cutter to a power drill/ reamer. Align the two round projections on the mill cutter with the top slot of the Spout Mill Guide. Check the version of the Spout Mill Guide by moving the Spout Mill Cutter down the guide and assessing the position of the cutter relative to the proximal medial calcar (Fig. 26).



Fig. 25

Fig. 26

When the orientation of the Spout Mill Guide is satisfactory, turn on the drill/driver. Pass the Spout Mill Cutter down the femur while maintaining lateral pressure on the cutter. The slots in the Spout Mill Guide will direct the cutter in a path that matches the geometry of the proximal body spout (Fig. 27). When the cutter reaches the bottom of the guide, turn off the drill/driver power and remove the Spout Mill Assembly. Do not remove the cutter while the power is on as this may remove additional bone. Preparation of the proximal femur is now complete.

Note: If preparation was made for a 45mm or 55mm Spout Body, a Cone Body of the same size can still be used if it is determined that more version is needed. Proximal support superior to the mid-stem modular junction is required, regardless of body type selected. The use of the Spout Mill Guide may not be necessary due to existing bone loss.

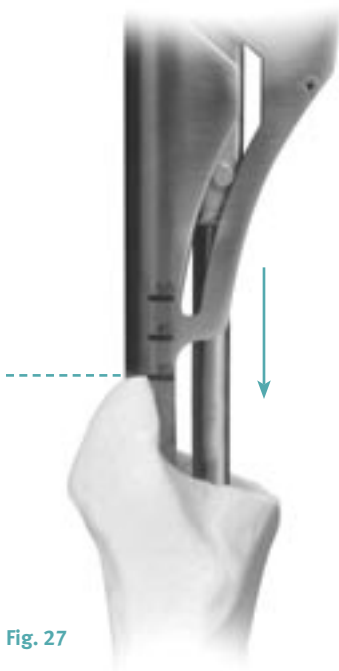

Fig. 27

3 – Trial Reduction

Before inserting the final prosthesis, perform a trial reduction to assess leg length, abductor muscle tension, joint stability, and range of motion. If it is difficult to seat the provisional in the femur, there may be a need for additional reaming and/or milling to remove impinging bone. Assess the fit again with the provisional construct. The Stem Provisionals are undersized one millimeter compared to the actual implants of the same size, so it is not possible to judge the ease of insertion of the definitive implant with the provisionals.

There are Distal Stem Provisionals and Proximal Body Provisionals that match all the implants in the ZMR Hip System. Based on the instruments used to prepare the femur, choose the corresponding provisional body and stem.

If a straight distal stem component will be used, attach the Proximal Body Provisional to the straight Distal Stem Provisional using the captured Compression Nut. While securing the Proximal Body Provisional with the Proximal Body Wrench, use the Nut Driver and Torque Wrench to torque the nut clockwise to 15N-m (130 in.-lbs.) (Fig. 28).

Attach the preoperatively planned Femoral Head Provisional to the trunnion of the Proximal Body Provisional. Insert the provisional construct into the femoral canal and perform a trial reduction. To evaluate joint stability, leg length, and offset, insert different provisional femoral head/neck combinations and body options, if needed.

With the provisional construct in place, assess the ability of the femur to support the proximal body above the mid-stem modular junction. If the proximal body cannot be adequately supported by bone grafting or other adjunctive reinforcement, an alternative implant may be appropriate.

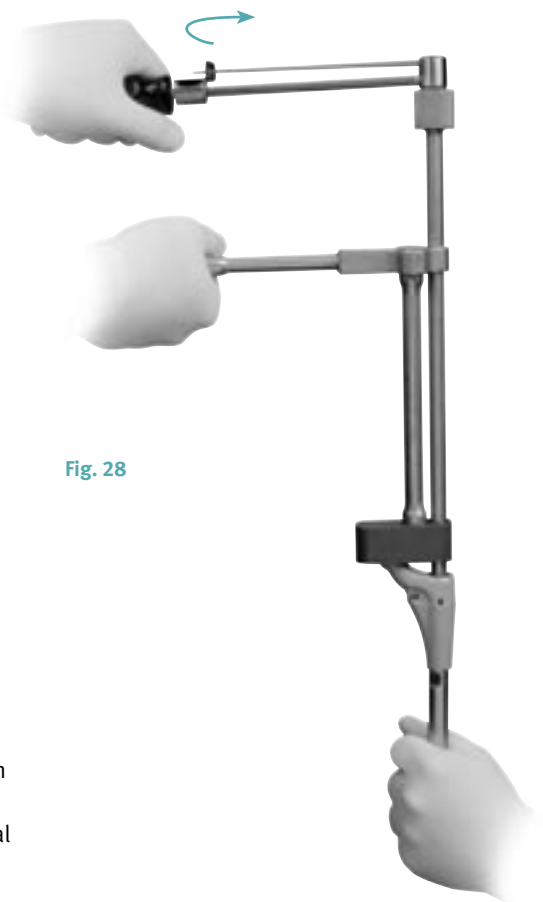

Fig. 28

If a bowed distal stem component will be used, follow the same procedure as above, with one exception. In order to orient the proximal body in the correct version relative to the bow of the distal stem, the provisional body and stem should be loosely secured prior to insertion down the femoral canal. Once the provisional construct is placed in the femur, adjust the Proximal Body Provisional to the correct orientation in relation to the Distal Stem Provisional. Use the Stem Alignment Guide to check the orientation of the bow by rotating the arm to center over the neck and locking it in position (Figs. 29, 29a, & 29b).

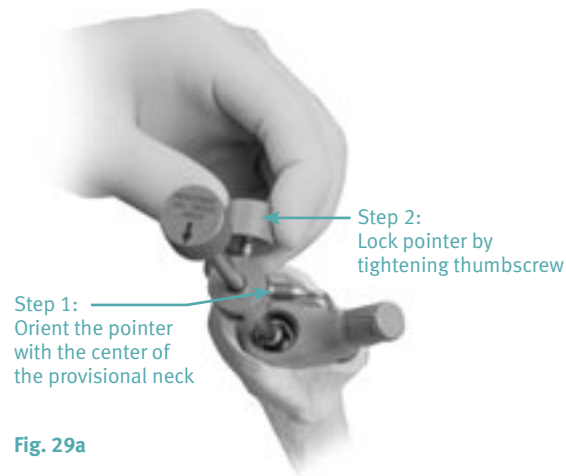

Fig. 29a

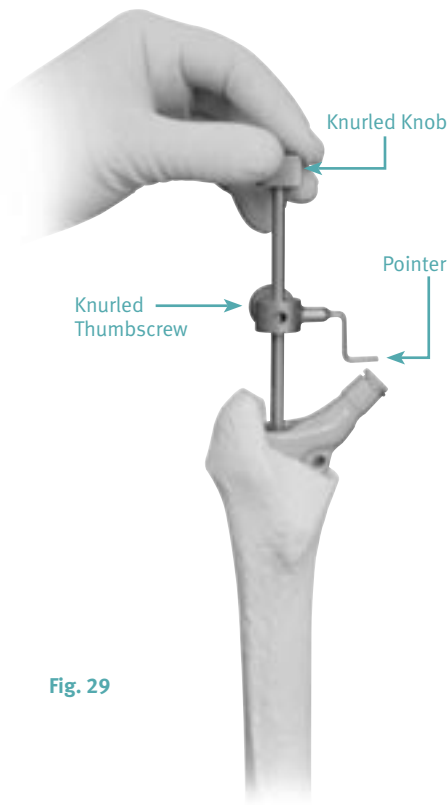

Fig. 29



Fig. 29b

Warning: Arrow on Knurled Knob must coincide with stem tip direction (bow).

When this position is acceptable, tightly secure the Proximal Body Provisional to the Distal Stem Provisional by using the Proximal Body Wrench, Nut Driver, and Torque Wrench. Tighten the Compression Nut to 15N-m (130 in.-lbs.) while the provisional assembly is in the femur (Fig. 30).

Using the Provisional Body Wrench will counter the tightening torque and minimize the risk of fracturing the femur during in situ tightening. Once tightened, proceed with the trial reduction.

Mark the orientation of the body on the bone as a reference to achieve the same version with the final implant. Then remove the provisional components and note the position of the proximal body relative to the bow of the distal stem.



Fig. 30

4 — Implantation

A — Back Table Assembly Technique

If desired, the implant can be completely assembled before insertion. This back-table assembly is typically used for a straight stem, but can also be used for a bowed stem if the orientation of the distal stem and proximal body is certain.

Before assembling the implant on the back table, inspect the body and stem tapers to make sure they are clean and dry.

With a bowed stem, it is particularly important to orient the proximal body component in the correct position relative to the distal stem component. The short axis of the oval indent on top of the stem is aligned with the bow. Place the proximal body component loosely onto the distal stem component so the alignment matches that of the provisional construct used earlier. Insert the Stem Alignment Guide into the stem and rotate the stem until proper version is achieved.

Press the body and stem components together by hand for initial locking. Insert the Junction Assembly Instrument through the body counterbore, and secure it by engaging the threads of the distal stem and turning the knurled handle of the Junction Assembly Instrument.

If the Junction Assembly Instrument does not easily thread onto the stem, do not force it. Instead, remove the Junction Assembly Instrument and realign it to prevent cross threading.

Once the assembly instrument is securely fastened, squeeze the two handles together until the needle deflects to the indicator mark on the handle (Fig. 31). If the handles squeeze completely together before the needle is adequately deflected, tighten the knurled handle more to spread the handles further apart. Then reapply pressure to the handles until the needle deflects to the indicator mark.

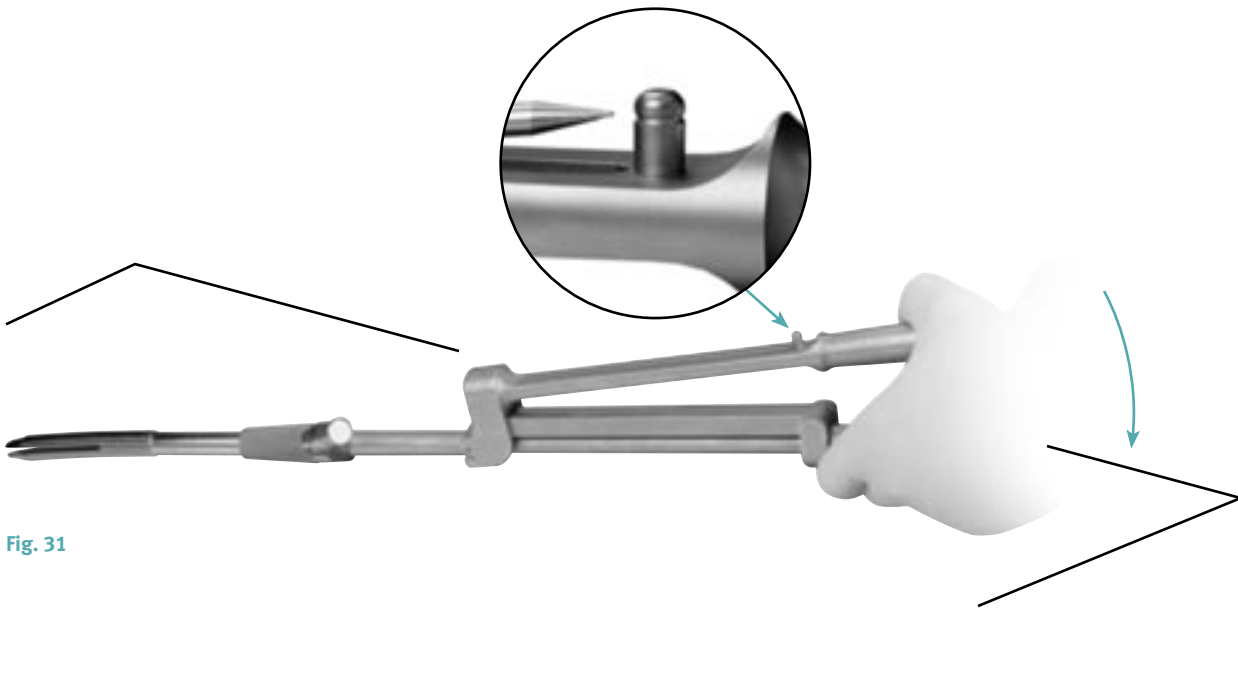

Fig. 31

Warning: Incorrect orientation of the knurled knob arrow will result in incorrect implant assembly.

After the mid-stem modular junction has been securely locked, insert and tighten the Compression Nut, which is packaged with the distal stem. Use the Proximal Body Wrench to secure the proximal body, and insert the Torque Wrench with Nut Driver into the body counterbore to engage the Compression Nut. Turn the Torque Wrench clockwise to 15N-m (130 in.-lbs.) (Fig. 32). Do not overtighten the Compression Nut as this could compromise its function. The assembled construct is now ready for insertion down the femoral canal.



Fig. 32

Insert the construct down the femoral canal by hand until it will no longer advance. Assess the implant for proper rotational alignment before impacting (Fig. 33). Then insert the Stem Impactor into the counterbore of the body, aligning it with the oval slot of the distal stem. Use the Mallet to drive the Stem Impactor and seat the implant in the femur.

The markings on the impactor serve as a reference (keyed off the greater trochanter) to the corresponding body height to assess the proper implant depth (Fig. 34). If the implant does not advance with each blow of the Mallet, stop insertion and remove the component. Then ream or mill additional bone from the areas that are preventing insertion and insert the component again.

With the implant construct in place, assess the support of the femur and/or adjunctive reinforcement to the proximal body.

Warning: Stem fracture, particularly in heavy, physically active patients, is most likely to occur in a prosthesis that is not supported proximally. Use of the ZMR XL should be considered for such patients.



Fig. 33



Fig. 34

B – “Loose” Assembly Technique

If the alignment of the proximal body and the distal stem is uncertain, assemble the components loosely. Do not engage the taper, but loosely thread the Compression Nut, which is packaged with the distal stem, onto the distal stem.

Insert the loosely assembled prosthesis into the canal, allowing the proximal body to rotate into the appropriate orientation relative to the distal stem. Use the Stem Impactor and Mallet to impact the prosthesis to its final position. The markings on the impactor serve as a reference (keyed off the greater trochanter) to the corresponding body height to assess the proper implant depth (Fig. 35). The implant should advance with each moderate blow of the Mallet. If it does not, remove the implant and perform additional reaming.

Rotate the proximal body into the desired version. Then use the Nut Driver to remove the Compression Nut. Insert the Junction Assembly Instrument through the body counterbore and secure it by engaging the threads of the distal stem and turning the knurled handle.

When securely fastened, squeeze the two handles together until the needle deflects to the indicator mark on the handle. If this is not achieved on the first attempt, retighten the assembly and repeat this step.

Remove the Junction Assembly Instrument. Then re-insert and tighten the Compression Nut. Use the Proximal Body Wrench to secure the proximal body, and insert the Torque Wrench with Nut Driver into the body counterbore to engage the nut. Turn the Torque Wrench clockwise to 15N-m. Do not overtighten the Compression Nut as this could compromise its function.

With the implant construct in place, assess the support of the femur and/or adjunctive reinforcement to the proximal body.

Warning: Stem fracture, particularly in heavy, physically active patients, is most likely to occur in a prosthesis that is not supported proximally. Use of the ZMR XL should be considered for such patients.

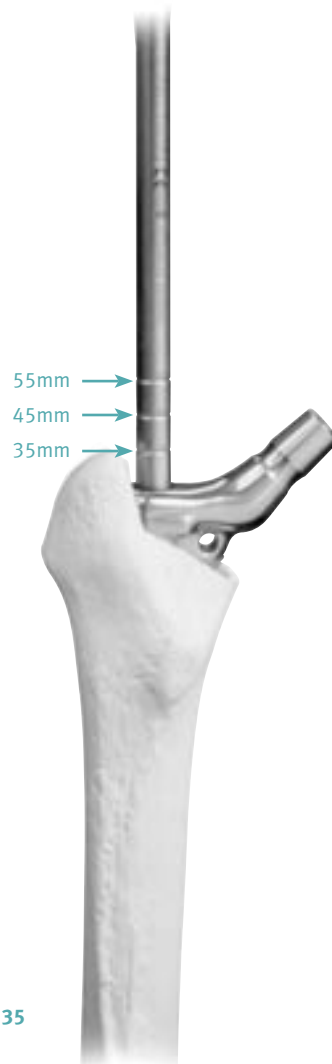

Fig. 35

Femoral Head Assembly

Once the implant is fully seated in the femoral canal, place the selected Femoral Head Provisional onto the taper of the implant. Perform a trial reduction to assess joint stability, range of motion, and restoration of leg length and offset.

When the appropriate femoral head implant is confirmed, remove the Femoral Head Provisional. Thoroughly clean and dry the taper on the femoral head component. Then place the selected femoral head on the taper and twist it slightly to secure it. **Impact it by striking the Head Impactor with one sharp blow of the Mallet.** Test the security of the head fixation by trying to remove it by hand.

Reduce the hip and assess leg length, range of motion, stability, and abductor tension.

Note: Always check that the neck taper and inside taper of the femoral head are clean and dry before impaction. Also, do not impact the femoral head onto the taper before driving the prosthesis down the femoral canal as the femoral head may loosen during impaction of the implant.

Wound Closure

After obtaining hemostasis, insert a Hemovac® Wound Drainage Device, if desired. Then close the wound in layers.

Postoperative Management

The postoperative management of patients with the *ZMR* Porous Revision Implant is determined by the surgical technique, patient bone quality, patient activity level, fit of the implant, and the surgeon's judgment. Weight bearing after revision surgery requires more external support for a longer period due to the nature of the extensive surgery and bone disruption.

Note: Accepted practices of postoperative care should be followed. The patient must be informed and made aware of the limitations of total joint reconstruction and the necessity of limiting weight and physical activity to protect the femoral stem from unnecessary stresses. In patients where proximal support was not achievable, additional risk may be present.

Implant Removal

In the event that the *ZMR* Porous Revision Implant must be removed, specially designed instruments are available to remove the implant. Make sure that all bone and soft tissue proximal to the implant are removed. Begin by removing the Compression Nut from the implant. It is important to use the Proximal Body Wrench to stabilize the implant and not stress the femur when using the Torque Wrench and Nut Driver to loosen the nut (Fig. 36). Failure to do so may result in fracture of the femur. Once the Proximal Body Wrench has secured the implant body, attach the Nut Driver to the Torque Wrench and insert it into the body counterbore to engage the Compression Nut. Then turn the Torque Wrench counterclockwise to loosen the nut.



Fig. 36

Remove the Compression Nut and attach the Distal Stem Extractor to the distal stem through the counterbore in the body by threading the extractor onto the threads in a clockwise direction. Engage as many threads as possible until tight (Fig. 37). **Be careful not to cross-thread the Distal Stem Extractor and stem.** If the Distal Stem Extractor is difficult to turn while threading it onto the stem, remove and realign the extractor.

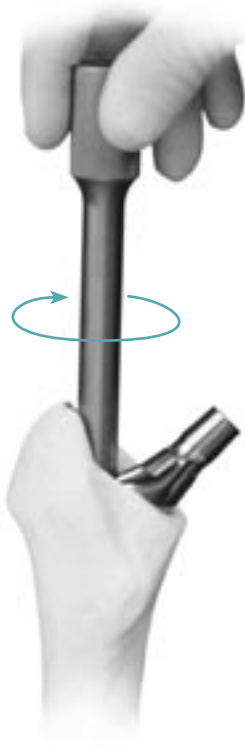

Fig. 37

When the Distal Stem Extractor is completely engaged, attach the Slaphammer to the extractor by turning the Slaphammer handle clockwise to engage the threads of the extractor. Turn the handle until tight. Reverse impact the stem from the canal by moving the Slaphammer weight (Fig. 38).

The leg should be firmly held and the direction of force of the Slaphammer should be in line with the implant and femur. Extracting in a direction that is not in line with the femur may cause fracture of the femur.



Fig. 38

An additional option using an extractor hook is available for use only with the Spout or Calcar Bodies. The Spout Bodies and Calcar Bodies have extraction holes to accept the Extractor Hook (Cat. No. 00-6601-002-00) (Fig. 39). Thread the Extractor Hook to the Slaphammer by turning the hook in a clockwise direction. Then reverse impact the stem from the canal by moving the Slaphammer weight.

Note: If the Compression Nut cannot be removed, impact a carbide punch into the inferior surface of the implant neck and drive the implant out of the canal with a Mallet.

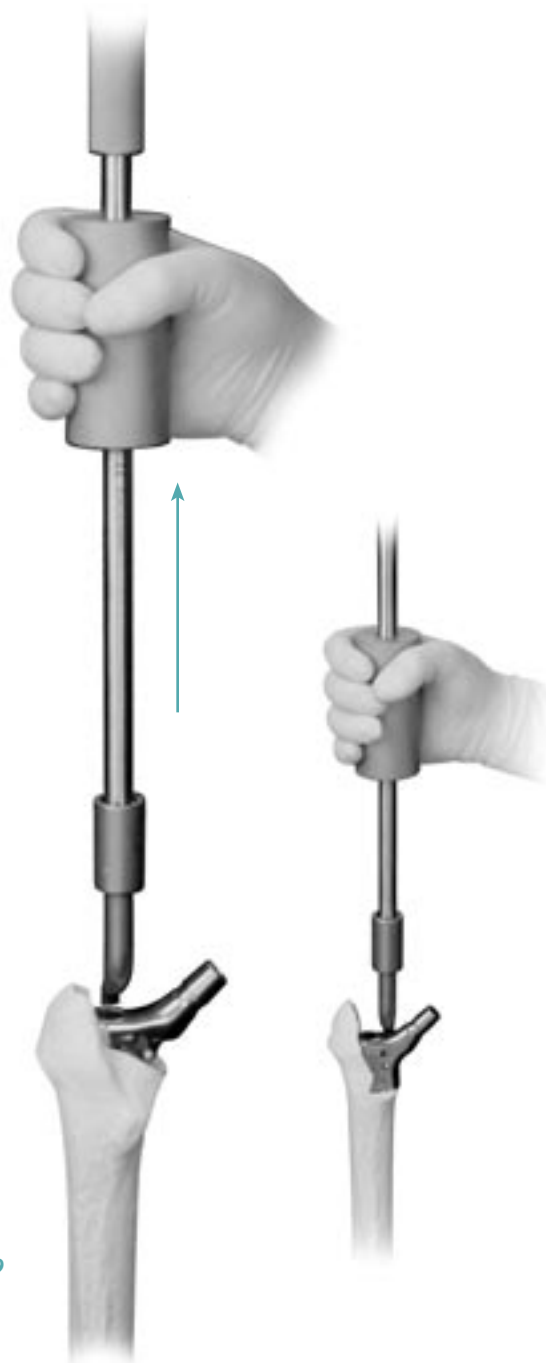
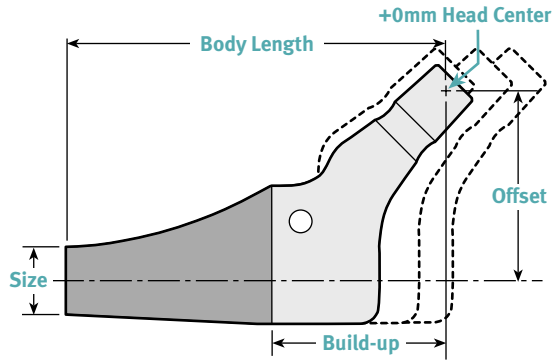

Fig. 39



Spout Body Options

Size (mm)	Size w/Plasma (mm)	Build-up Options (mm)	Offset Options (mm)	Body Length Options (mm)
AA-	16.7	35	36	75
	16.7	35	40	75
AA	16.7	35	36	80
	16.7	35	40	80
A	17.7	35*	40*, 46	80
	17.7	45	46	90
	17.7	55	46	100
B	18.9	35*	40*, 46	80
	18.9	45	46	90
	18.9	55	46	100
C	20	35*	40*, 46	80
	20	45	46	90
	20	55	46	100
D	21.2	35*	40*, 46	80
	21.2	45	46	90
	21.2	55	46	100
E	22.5	35*	40*, 46	80
	22.5	45	46	90
	22.5	55	46	100
F	23.7	35*	40*, 46	80
	23.7	45	46	90
	23.7	55	46	100

* 40mm offset only provided with 35mm build-up Spout Body. Build-up, offset, and body length dimensions shown at +0mm head center.

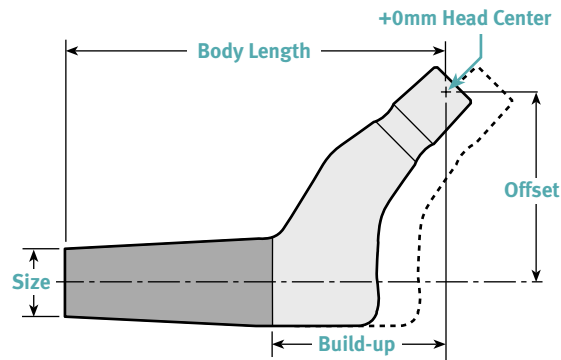

Cone Body Options

Size (mm)	Size w/Plasma (mm)	Build-up Options (mm)	Offset Options (mm)	Body Length Options (mm)
AA-	16.7	35	36	75
	16.7	35	40	75
AA	16.7	35	36	80
	16.7	35	40	80
A	17.7	45	46	90
	17.7	55	46	100
B	18.9	45	46	90
	18.9	55	46	100
C	20	45	46	90
	20	55	46	100
D	21.2	45	46	90
	21.2	55	46	100
E	22.5	45	46	90
	22.5	55	46	100
F	23.7	45	46	90
	23.7	55	46	100

Build-up, offset, and body length dimensions shown at +0mm head center.

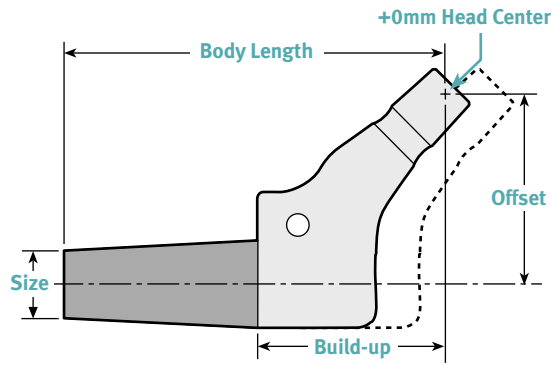

Calcar Body Options

Size (mm)	Size w/Plasma (mm)	Build-up Options (mm)	Offset Options (mm)	Body Length Options (mm)
AA-	16.7	35	36	75
	16.7	35	40	75
AA	16.7	35	36	80
	16.7	35	40	80
A	17.7	45	46	90
	17.7	55	46	100
B	18.9	45	46	90
	18.9	55	46	100
C	20	45	46	90
	20	55	46	100
D	21.2	45	46	90
	21.2	55	46	100
E	22.5	45	46	90
	22.5	55	46	100
F	23.7	45	46	90
	23.7	55	46	100

Build-up, offset, and body length dimensions shown at +0mm head center.

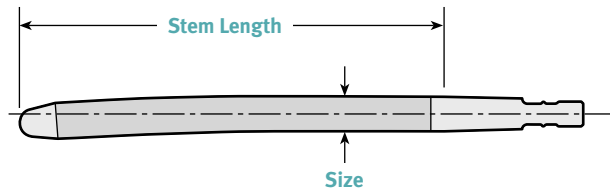

Distal Stem Dimensions

Size (mm)	Splined Stems Length (mm)			Porous Stems Length (mm)			
	115	170	220	115	170	220	260
12	S	S, B		S	S, B, L		
13.5	S	S, B	B	S	S, B, L	B, L	
15	S	S, B	B	S	S, B, L	B, L	L
16.5	S	S, B	B	S	S, B, L	B, L	L
18	S	S, B	B	S	S, B, L	B, L	L
19.5	S	S, B	B	S	S, B, L	B, L	L
21		S, B	B		S, B, L	B, L	L
22.5		S, B	B		S, B, L	B, L	L
24		S, B	B		S, B, L	B, L	L
25.5		S, B	B		S, B, L	B, L	

S denotes available in a straight stem, B denotes available in a bowed stem, L denotes available in slotted bowed stem.

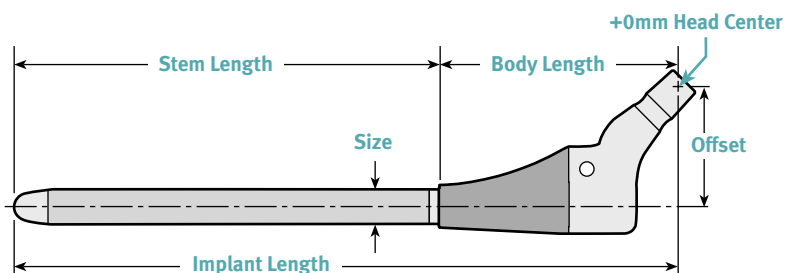

Assembled Implant Length*

Body Length (mm)	+	Stem Length (mm)	=	Implant Length (mm)
75		115		190
75		170		245
75		220		295
75		160		335
80		115		195
80		170		250
80		220		300
80		260		340
90		115		205
90		170		260
90		220		310
90		260		350
100		115		215
100		170		270
100		220		320
100		260		360

* Using +0mm Head Center



References

1. Barden B, et al. Supportive strut grafts for diaphyseal bone defects in revision hip arthroplasty. *Clin Orthop*. 2001;387:148-155.
2. Head WC, et al. Onlay cortical allografting for the femur. *Orthopaedic Clinic of North America*. 1998;29(2):307-312.
3. Head WC, et al. Structural bone grafting for femoral reconstruction. *Clin Orthop Rel Res*. 1999;379:223-229.
4. Hardings K. The direct lateral approach to the hip joint. *J Bone Joint Surg*. 1982;64B:17-19.
5. Marcy GH, Fletcher RS. Modification of the posterolateral approach to the hip for insertion of a femoral head prosthesis. *J Bone Joint Surg*. 1954;36:142-3.
6. Charnley J, Ferreira A. Transplantation of the greater trochanter in arthroplasty of the hip. *J Bone Joint Surg*. May, 1964;46B:191-197.
7. McGroarty BJ, Bal S, Harris WH. Trochanteric Osteotomy for total hip arthroplasty: six variations and indications for their use. *J Am Acad Orthop Surg*. Sept/Oct, 1996;4 (5):258-267.
8. Glassman AH, Engh CA, Bobyn JD. A technique of extensile exposure for total hip arthroplasty. *J Arthroplasty*. 1987;2:11-21.
9. Masri BA, Campbell DG, Garbus DS, Duncan CP. Seven specialized exposures for revision hip and knee replacement. *The Orthopaedic Clinics of North America*. April, 1998;29 (2):229-240.
10. Younger TI, Bradford MS, Magnus RE, Paprosky WG. Extended proximal femoral osteotomy: a new technique for femoral revision arthroplasty. *J Arthroplasty*. June, 1995;10: 329-338.
11. Aribindi R, Paprosky W, Nourbash P, Kronick J, Barba M. Extended trochanteric osteotomy. Instructional Course Lectures. 1999;48:19-26.
12. Agnew SG, Stewart CL, Skinner R, et al. Design influence on pressure and temperature generation from intramedullary reamers: in vitro and in vivo models. Presented at the Orthopaedic Trauma Association Annual Meeting. Tamp, FL; September, 1995.

Please refer to package insert for complete product information, including contraindications, warnings, precautions, and adverse effects.

Contact your Zimmer representative or visit us at www.zimmer.com



Barcode Needed