

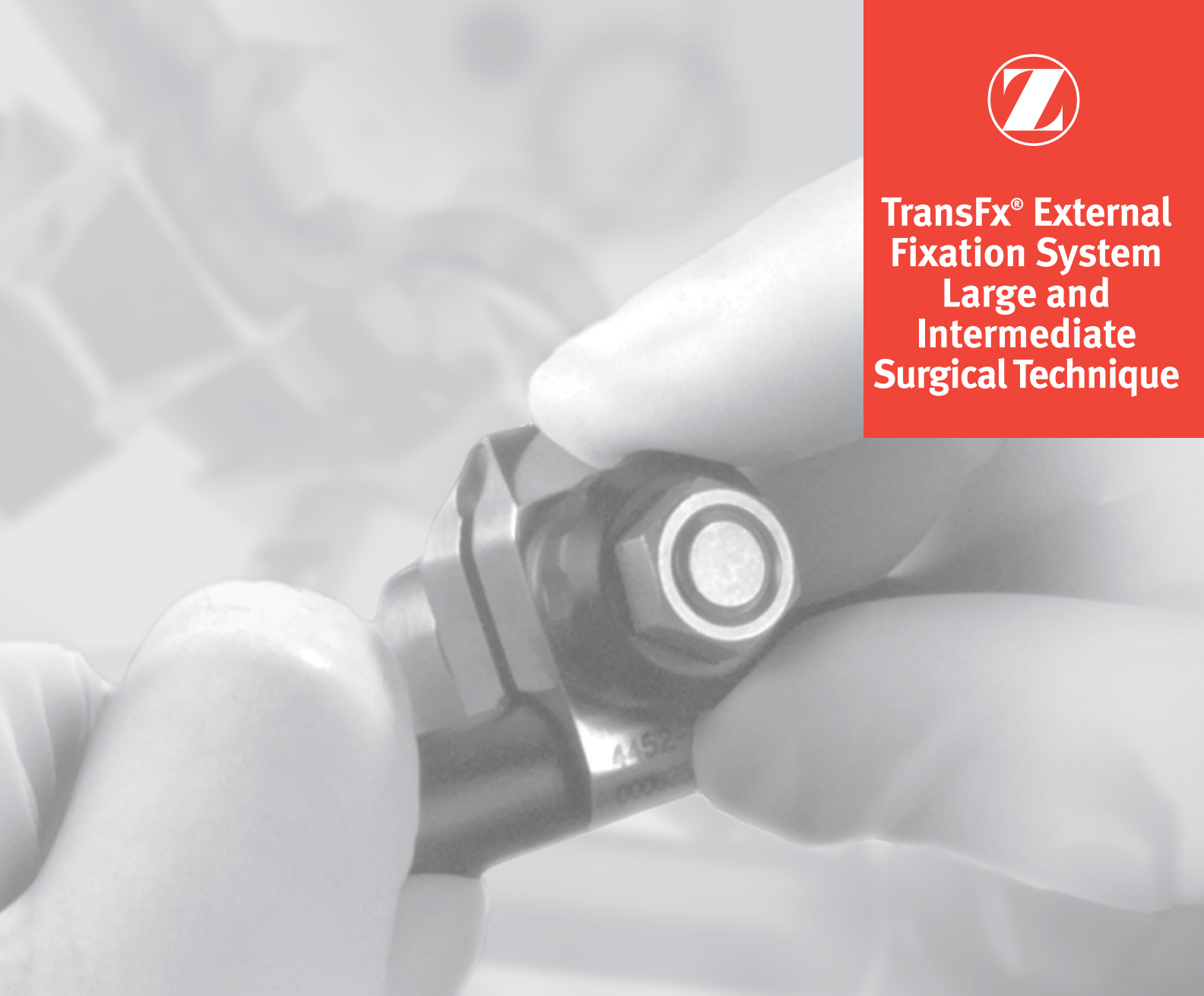

**TransFx® External  
Fixation System  
Large and  
Intermediate  
Surgical Technique**





## **Surgical Technique For TransFx External Fixation System Large - Intermediate**

### **Table of Contents**

<b>Introduction</b>	<b>2</b>
<b>Design Rationale</b>	<b>3</b>
Design Goals	3
Dynamization	3
Basic Frame Configurations	4
<b>System Components</b>	<b>5</b>
Large/Intermediate Components	5
Pins	6
Clamps	7
Rods	8
Instruments	9
<b>Pathways for Pin Insertion</b>	<b>10</b>
Leg Zone A	10
Leg Zone B	11
Leg Zone C	12
Leg Zone D	13
<b>Techniques</b>	<b>14</b>
Pin Insertion	14
Frame Construction	16
Sample Frames	21
<b>Postoperative Care</b>	<b>24</b>

## Introduction

In 1897, Dr. Clayton Parkhill of Denver, Colorado, reported on the first successful use of an external fixation device in fracture treatment. Five years later, Dr. Albin Lambotte of Belgium developed a unilateral fixator that allowed active motion without splinting. Lambotte's more rigid device was made of better materials, and used more pins in combination with steel rods.

In the 1930s, Dr. Roger Anderson developed the concept of independent pin placement with individual pin-to-bar clamps. At about the same time, Dr. Raoul Hoffman developed the multi-pin clamp technique.

Over the next 60 years, external fixators continued to become more rigid. In most cases, they were used as a primary means of fracture management. Since the 1980s, however, the use of external fixation has evolved to become a temporary way to support soft tissues and maintain fracture alignment until a more definitive procedure such as a periarticular plating or IM nailing can be performed.

The flexibility of more contemporary devices gives the surgeon the ability to progressively increase the frame rigidity while allowing physical therapy or weight bearing, and then decrease frame rigidity prior to complete removal of the frame.

The *TransFx*® External Fixation System is a modular system that offers the surgeon advances in design technology and materials. The system design philosophy is to provide the surgeon with choices in frame construction, simplicity in frame components, and ease of transition from one frame size to another. Indications for the *TransFx* System include fractures of the long bones and pelvis, joint fusion, limb lengthening, osteotomies, and periarticular fractures.



## Design Rationale

### Design Goals

The most important functional design goal of an external fixation system is to provide the necessary stability to the fracture. Stability is affected by a number of factors, including:

- **Material Strength** – An external fixation device must be able to withstand the loads applied by an active patient.
- **Pin Spacing** – The rigidity of a frame is increased when pins within the same fragment are spaced farther apart.
- **Proximity of Rod-to-Bone** – Rigidity is also increased when the rod is placed closer to the bone.
- **Diameter of Rods and Pins** – The greater the cross-sectional area of the rods and pins, the stronger the frame.
- **Number of Pins, Rods, and Frames** – Adding pins, stacking rods, and/or creating an additional frame in a different plane (Delta Frame) can enhance the rigidity of the construct.
- **Pin Angles** – Pins must be inserted at angles that allow optimal bone purchase and fracture reduction.

In addition to providing the desired functional stability, the general goals of an external fixation system design are to provide a wide choice of frame construction options, flexibility in pin placement and orientation, simple application of the construct, and easy transition among frame sizes to accommodate specific patient anatomy and fracture type.

### Frame Construction Options

The *TransFx* External Fixation System is designed to provide multiple frame construction options by offering a variety of clamp designs, including rod-to-rod clamps, transition clamps, and single and multi-pin clamps. These options allow flexible pin positioning and flexible placement on the rods.

### Pin Placement and Orientation

Pin orientation should be dictated by patient anatomy and the characteristics of the fracture fragments. The clamps in the *TransFx* External Fixation System are universally adjustable to allow independent pin placement in three planes. This allows flexible configuration and positioning of the construct. Multi-pin clamps are available in single-, mid-, and end-connect options with choices of pin separation to further accommodate independent pin placement. Components are available in a wide selection of pin and rod diameters and lengths.

### Construct Stability

The pins and some clamps of the *TransFx* System are made from high strength stainless steel. Rods are made from carbon fiber, while multi-pin clamps are made primarily of carbon fiber and aluminum.

### Basic Frame Configurations

When utilizing pins in an external fixation procedure, two basic frame configurations are commonly used: unilateral frames and modular frames.

#### Unilateral Frames

When a single rod is attached with pins above and/or below a fracture site, the frame is considered to be unilateral. A unilateral frame does not allow for multiplanar manipulation of the fracture after the frame is applied. It can be adjusted only axially. The rigidity of a unilateral frame can be increased by adding additional pins, or by adding a second rod in a stacked configuration.

#### Modular Frames

Frames where pins and rods are individually attached to the fragments (fracture units) are known as modular frames. The pins are then connected through the use of multiple single-pin clamps and rods to achieve reduction and stability. Alternatively, the pins may be connected in pairs, using multi-pin clamps with a single rod. Modular frame configurations allow manipulation of the fracture in more planes to facilitate fracture reduction.

**NOTE:** A unilateral frame can be converted to a modular frame by changing the rod and clamp configuration as long as the inside pins are not placed too close together.

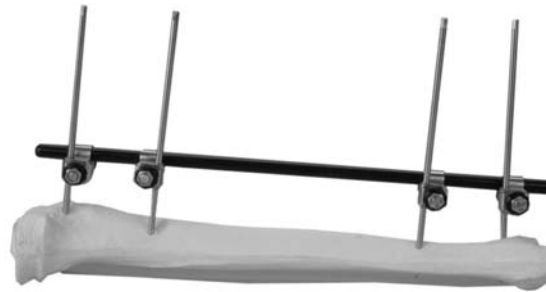

Unilateral Frame

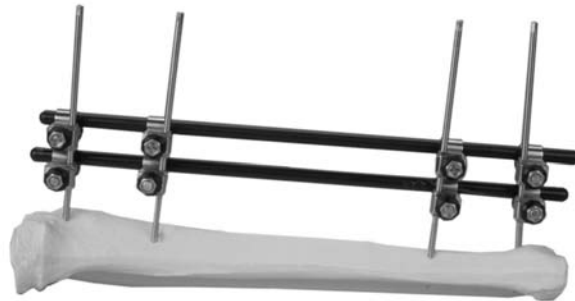

Stacked Unilateral Frame



Modular Frame

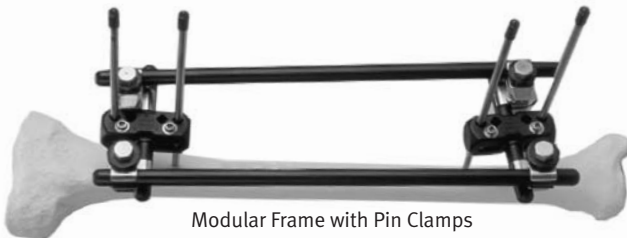

Modular Frame with Pin Clamps

## System Components

### Large/Intermediate Components

#### Pins

Self Drilling/Self Tapping

Self Tapping

Trocar Tip

Central Threaded Pin

#### Rods

8mm diameter

11mm diameter

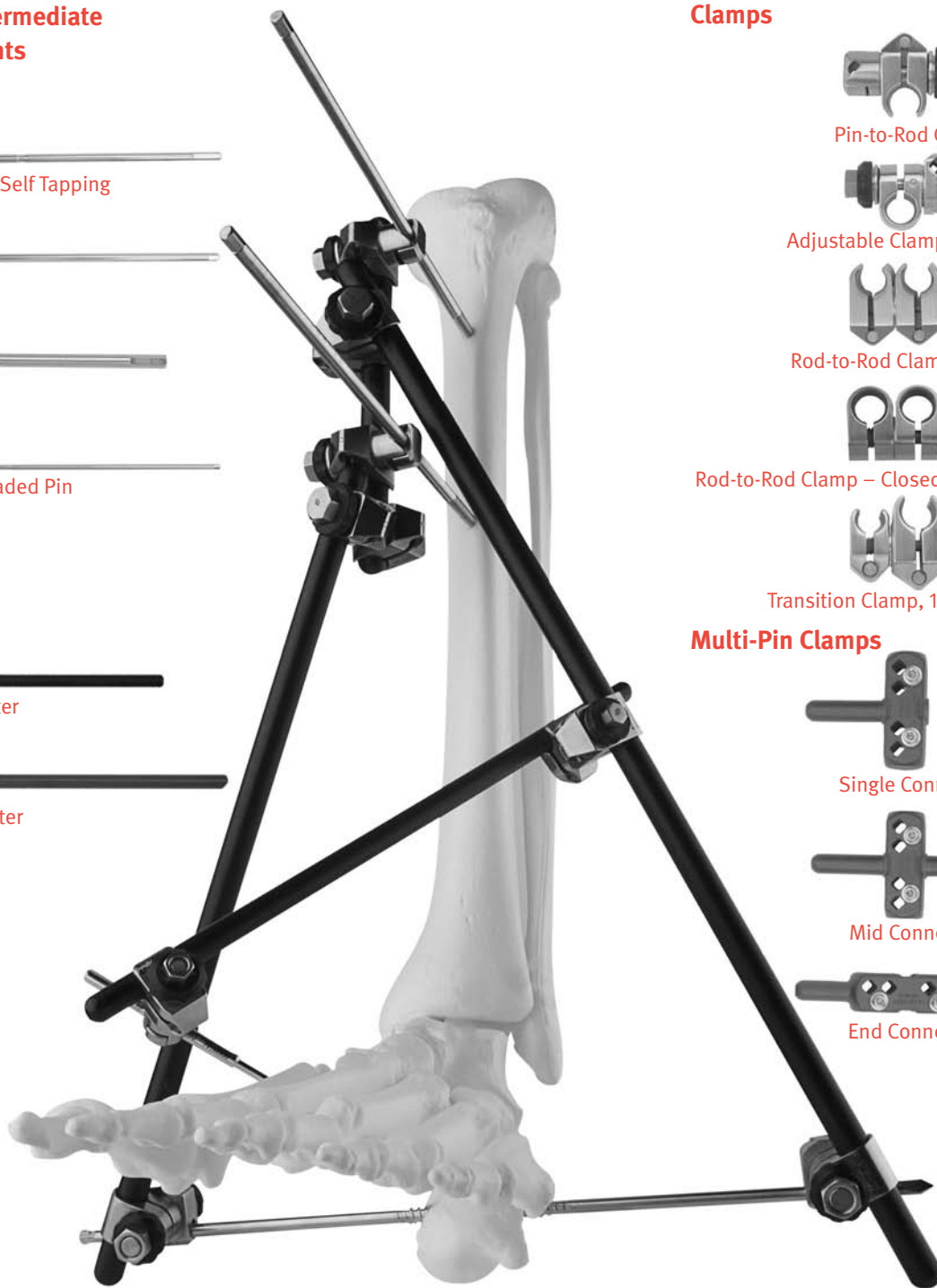

### Clamps



Pin-to-Rod Clamp



Adjustable Clamp (Large Only)



Rod-to-Rod Clamp – Open



Rod-to-Rod Clamp – Closed (Intermediate Only)



Transition Clamp, 11mm to 8mm

### Multi-Pin Clamps



Single Connect



Mid Connect



End Connect

## Pins

All pins are made of stainless steel

### Self-Tapping

Double Lead Threads:

- Faster insertion, requiring fewer turns
- More threads engaged in bone

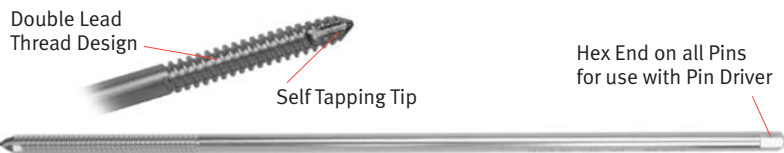

Pin Dia.	Material Grade	Thread Dia.	Lengths	Thread Type	Minor Dia.	Drill Required
6.0mm	22-13-5	6.0	200, 250	Dbl. Lead	4.7	4.5
5.0mm	22-13-5	5.0	125, 150, 175, 200, 250	Dbl. Lead	4.2	4.0
4.5mm	22-13-5	4.5	100, 125, 150, 175, 200	Dbl. Lead	3.7	3.5
4.0mm	22-13-5	4.0	80, 100, 120, 150	Dbl. Lead	3.2	3.0
3.5mm	316L	3.5	80, 100, 150	Dbl. Lead	2.7	2.5
3.0mm	316L	3.0	3.080, 150	Sngl. Lead	2.25	2.0

### Self-Drilling/Self-Tapping



Pin Dia.	Material Grade	Thread Dia.	Length	Minor Dia.
6.0mm	22-13-5	6.0	150, 200	5.4
5.0mm	22-13-5	5.0	150, 200, 250	4.4
4.5mm	22-13-5	4.5	150, 200	3.9
4.0mm	22-13-5	4.0	80, 150	3.4
3.5mm	22-13-5	3.5	80, 150	2.9
3.0/4.0mm	22-13-5	3.0	80, 100	2.4

### Trocar Tip



Pin Dia.	Material Grade	Thread Dia.	Length	Minor Dia.
3.0/4.0mm	22-13-5	3.0	80	1.8
2.5mm	316L	2.5	150, 200	1.75

- For use with Trocar Device

### Central Threaded Pin

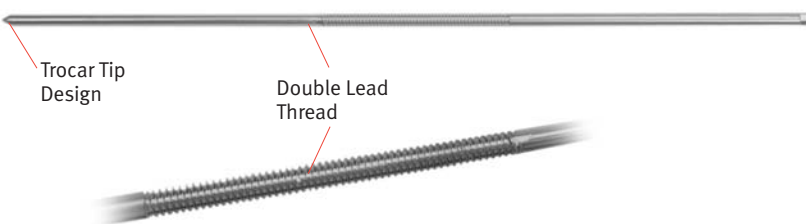

Pin Dia.	Material Grade	Thread Dia.	Length	Minor Dia.
5.0mm	22-13-5	5.0	300	4.2

- Attaches to Rod/Clamps from both sides of bone

## Clamps

### Pin-to-Rod Clamp

- Universally adjustable
- Independent pin placement in three planes
- Open clamp design for snap fit
- Speed nuts for initial finger tightening
- Spring action

Large: 4mm-6mm pins/11mm rods  
Intermediate: 2.5mm-4.5mm pins/8mm rods

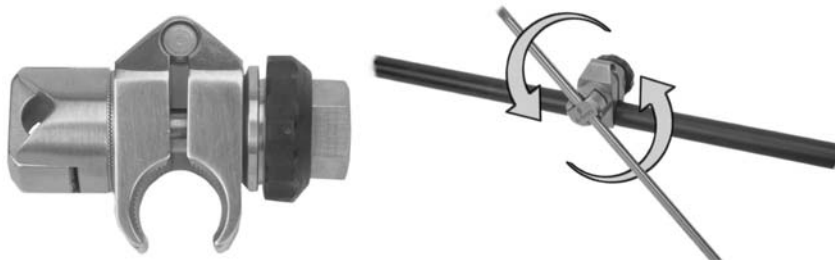

### Adjustable Clamp (Large Only)

- Independent loosening and tightening of rods and pins
- Universally adjustable
- Speed nuts for initial finger tightening
- Used when axial compression or distraction is necessary
- Accepts 11mm rods and 4mm-6mm pins and Schanz screws

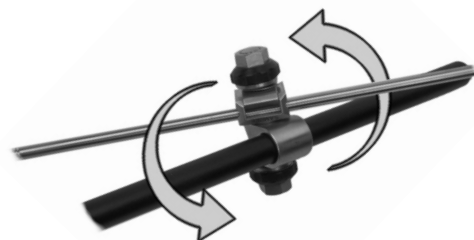

### Rod-to-Rod Clamp

- Universally adjustable
- Speed nuts for initial finger tightening

Large: 11mm rods  
Intermediate: 8mm rods



Open Design



Closed Design  
(Intermediate Only)

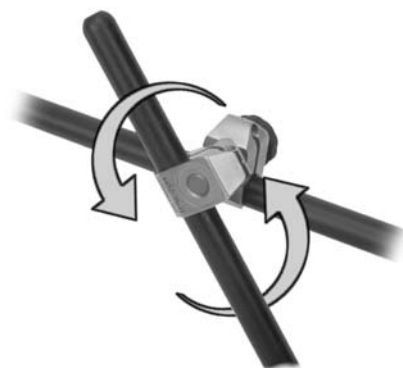

### Transition Clamp (11mm to 8mm)

- Ability to connect from large (11mm) to intermediate (8mm) systems
- Transition clamps available in 8mm to 4mm and 4mm to 3mm styles
- Three-dimensional clamp rotation
- Open clamp design for snap fit

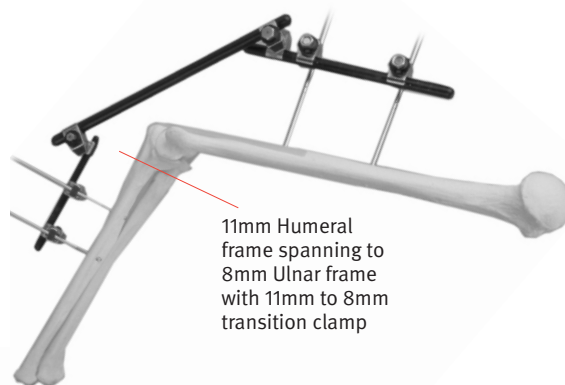
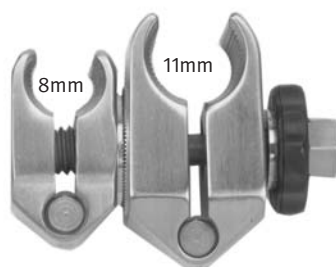

### Multi-Pin Clamp

- Three choices of pin separation
- Carbon fiber and aluminum
- Single, mid, and end-connect options
- Cam locking feature on pin tightens with Hex Screwdriver

Large: 11mm Rod and 4mm-6mm pin diameters  
Intermediate: 8mm Rod and 2.5mm-4.5mm pin diameters

**Note: In the event pins are wedged or trapped in the clamp, tap the screw head to release pins.**

**Note: TransFx Multi-Pin Clamps must be tightened using only the Hex Screwdriver.**

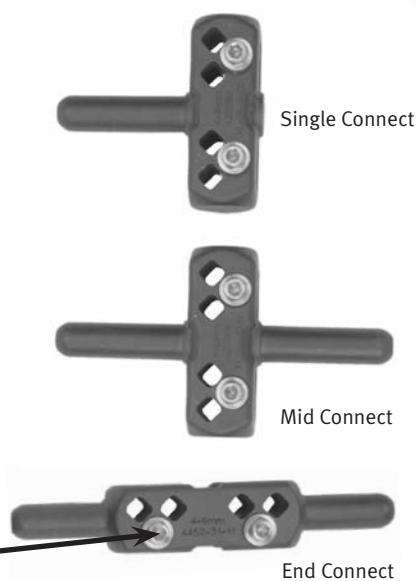

Hex Screwdriver for Large Multi-Pin Clamps (00-4450-052-00) or Intermediate Multi-Pin Clamps (00-4450-050-00)

### Rods

- Carbon fiber
- Rounded ends
- 11mm Rod (Large) available in 100/125/150/200/250/300/350/400/450/500/550/600/650mm lengths
- 8mm Rod (Intermediate) available in 60/80/100/120/140/160/180/200/220/240/300/350/400/450/500mm lengths
- Aluminum Angled Rod (Large): 135mm I.D. x 11mm and 180mm I.D. x 11mm

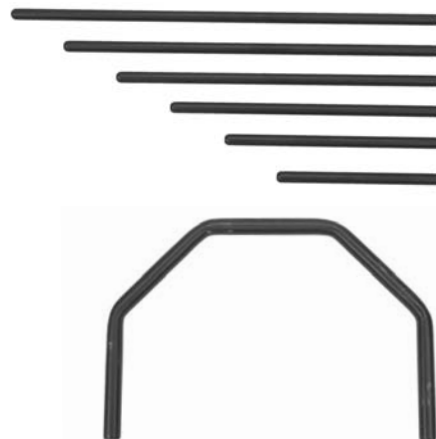
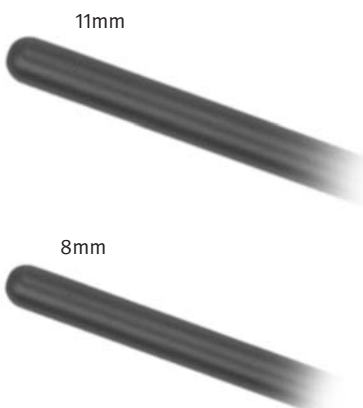

## Instruments

### Hex Pin Driver

- Interference-fit
- Hex Pin Driver inserts three pin diameters

Large: 4.5mm, 5mm, and 6mm  
Intermediate: 3mm, 3.5mm, and 4mm

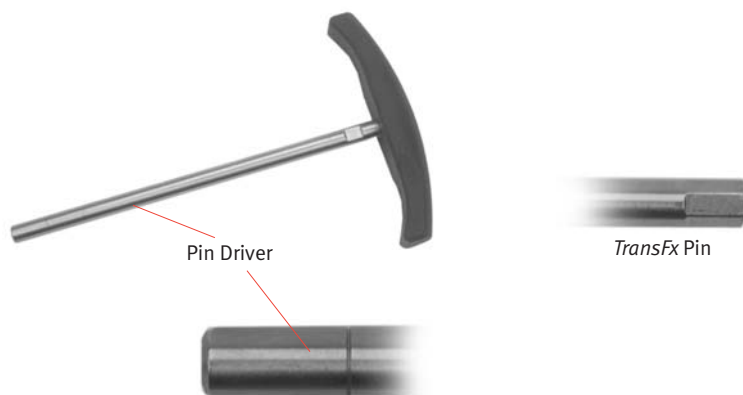

### Multi-Pin Drill Guide

- Five-position setting
- Four-hole drill guide with drill sleeve that corresponds to large and intermediate multi-pin clamps
- Threaded drill sleeve locks into position
- Available in large (11mm) and intermediate (8mm)



### Compression-Distraction Device (Large Only)

- Allows up to 50mm of compression or distraction
- Attaches to other rods using Rod-to-Rod Clamps



### Open Compressor (Large Only)

- Allows for compression or distraction up to 45mm
- Use in conjunction with adjustable clamp

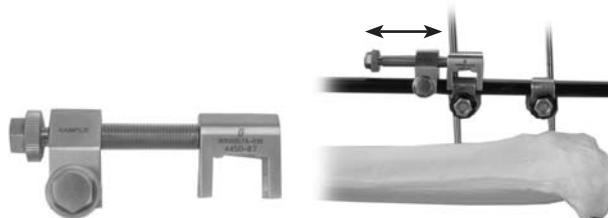

### Universal Chuck with T-Handle

- For use with all pin sizes (1.25mm to 6.0mm)



## Pathways for Pin Insertion

### Leg Zone A

#### Anatomic Considerations

1. The shape of the tibia changes rapidly through this zone.
2. The popliteal artery is posterior to the tibia where it divides into its terminal branches.
3. The superficial and deep peroneal nerves are lateral to the fibula as they wind around the fibular neck.
4. The saphenous nerve and greater saphenous vein are posterior to the tibia on the medial side of the limb.
5. In distal Zone A, the anterior tibial artery is on the anterior surface of the interosseous membrane and the peroneal and posterior tibial arteries are posterior to the tibia, accompanied by their associated veins.

#### Pin Placement

1. Full-pins (or half-pins) can be placed in the 90° medial/90° lateral direction throughout Zone A.
2. Pins can be placed parallel to the joint line (and to each other) through the condyles of the tibia in proximal Zone A.

Green SA. *Complications of External Skeletal Fixation—Causes, Prevention, and Treatment*. Charles C. Thomas Publisher; 1981 (used with permission).

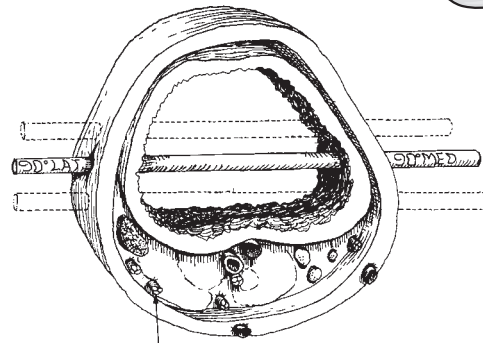
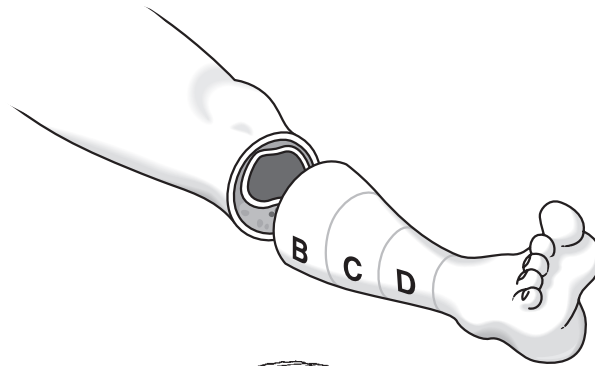

lat. sural cutaneous

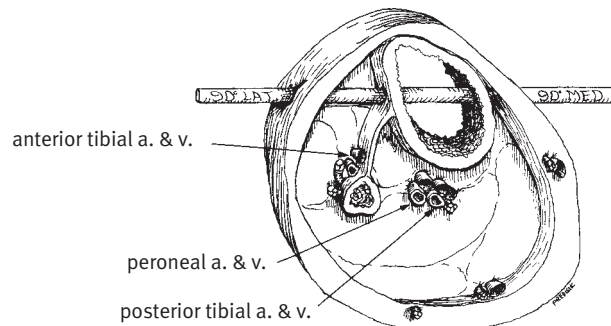
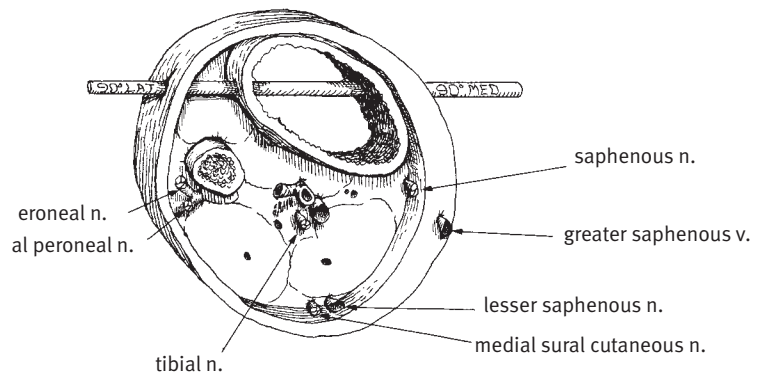

## Leg Zone B

### Anatomic Considerations

1. The tibia has a triangular cross section throughout Zone B, with the lateral surface relatively vertical, and the medial surface oblique.
2. The posterior tibial vessels, the tibial nerve, and the peroneal vessels maintain a constant relationship throughout Zone B with respect to the posterior surface of the tibia and the medial surface of the fibula.
3. The anterior tibial artery and vein, and the deep peroneal nerve, lie on the anterior surface of the interosseous membrane in Zone B, traversing from the anterior ridge of the fibula towards the lateral ridge of the tibia.

### Pin Placement

1. Full-pins (or half-pins) can be inserted from 90° lateral or 90° medial.
2. Half-pins can be inserted with caution from the 30° medial (or 45° medial) position perpendicular to the oblique medial surface of the tibia. The tip of the pin will penetrate the tibialis posterior muscle. Bear in mind the relationship of the peroneal artery and vein, adjacent to the medial corner of the fibula.

Green SA. *Complications of External Skeletal Fixation—Causes, Prevention, and Treatment*. Charles C. Thomas Publisher; 1981 (used with permission).

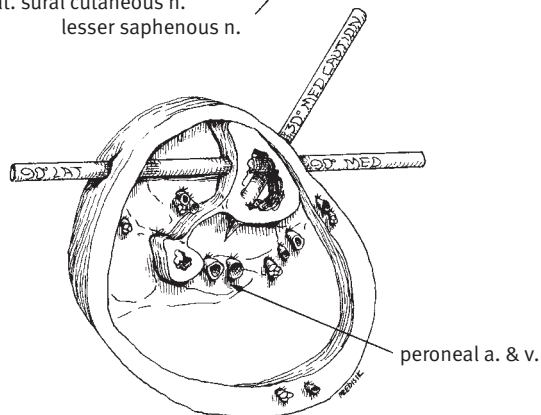
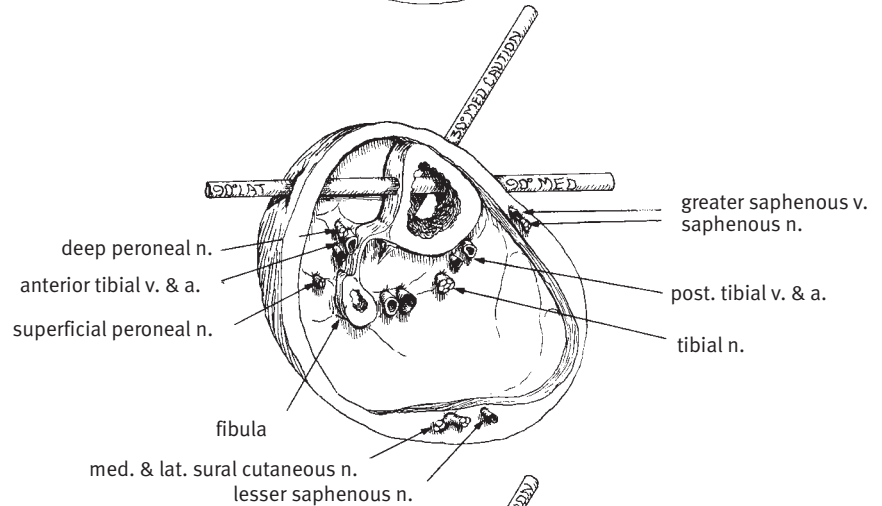
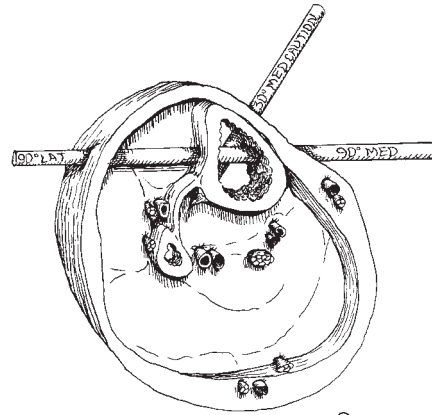
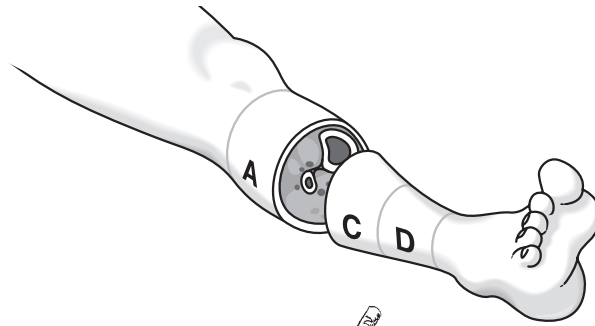

## Leg Zone C

### Anatomic Considerations

1. The tibia retains its distinctive triangular cross section.
2. The posterior tibial artery and vein and the tibial nerve remain posterior to the tibia and the peroneal vessels remain slightly medial to the fibula.
3. The anterior tibial artery and vein and the deep peroneal nerve have completed their traverse of interosseous membrane and are adjacent to the posterolateral corner of the tibia throughout Zone C. These structures begin to traverse the lateral surface of the tibia in distal Zone C.
4. The saphenous nerve and greater saphenous vein are located at the posteromedial corner of the tibia in the subcutaneous tissue.

### Pin Placement

1. In the upper part of Zone C, full- or half-pins can be safely placed from the 90° medial or 90° lateral direction.
2. Half-pins into the oblique medial surface of the tibia are difficult to place in Zone C because of the intimate relationship of the anterior tibial vessels to the bone. A 0° half-pin would be safe in distal Zone C, but it is technically difficult to place because of the obliquity and thickness of the bone.
3. In distal Zone C, placement from the 90° lateral or 90° medial position can endanger the anterior tibial artery and deep peroneal nerve.

Green SA. *Complications of External Skeletal Fixation—Causes, Prevention, and Treatment*. Charles C. Thomas Publisher; 1981 (used with permission).

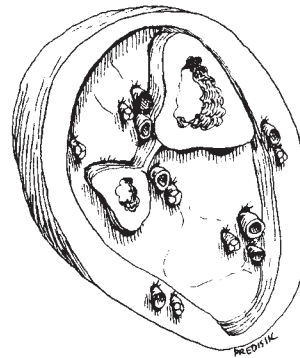
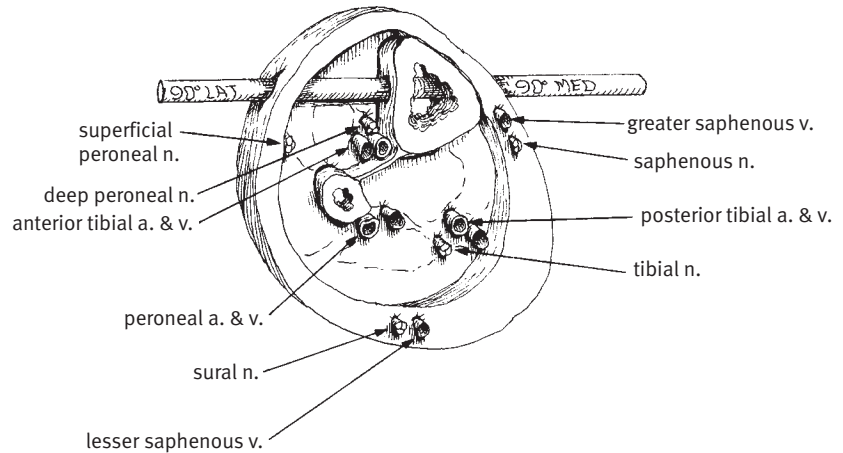
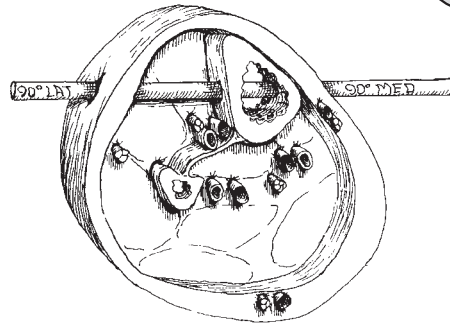
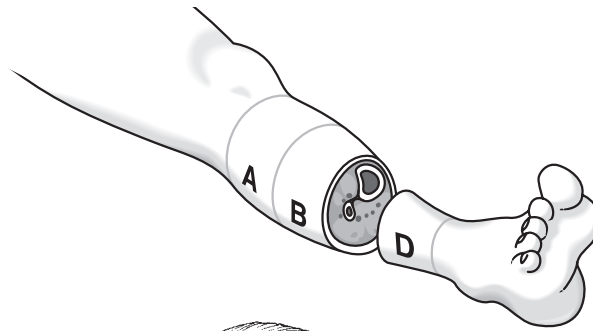

## Leg Zone D

### Anatomic Considerations

1. The posterior tibial artery and vein and the tibial nerve remain posterior to the tibia, traversing medially as they approach the ankle joint.
2. The anterior tibial artery and vein, and the deep peroneal nerve, are on the lateral surface of the tibia in proximal Zone D. They lie on the anterior surface of the tibia in distal Zone D.
3. The saphenous nerve and greater saphenous vein are on the medial side of the tibia throughout Zone D.
4. The superficial peroneal nerve has divided into its terminal branches in this zone.

### Pin Placement

1. Half-pins can be placed from the 30° medial position into the subcutaneous portion of the tibia.
2. Full-pin placement from the 90° medial and 90° lateral directions can be accomplished in the distal two-thirds of Zone D.
3. Full- or half-pin placement from 90° medial or 90° lateral can endanger the anterior tibial artery and deep peroneal nerve in the proximal one-third of Zone D.

Green SA. *Complications of External Skeletal Fixation—Causes, Prevention, and Treatment*. Charles C. Thomas Publisher; 1981 (used with permission).

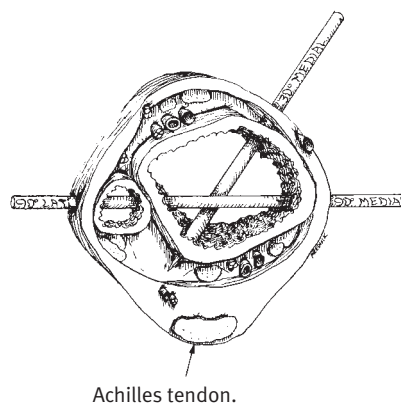
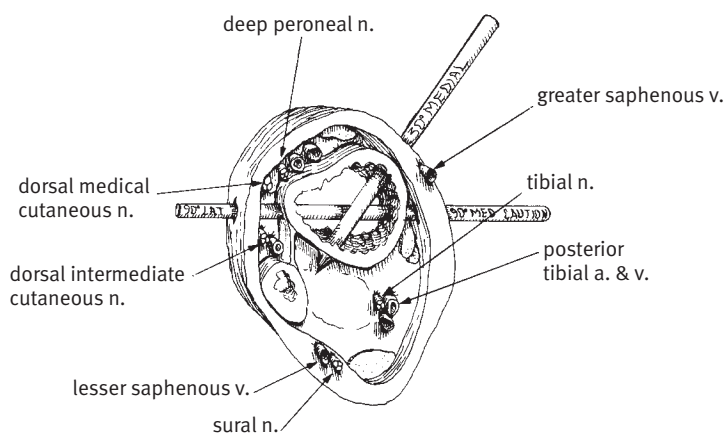
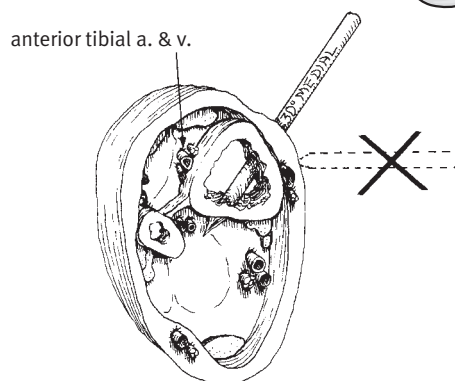
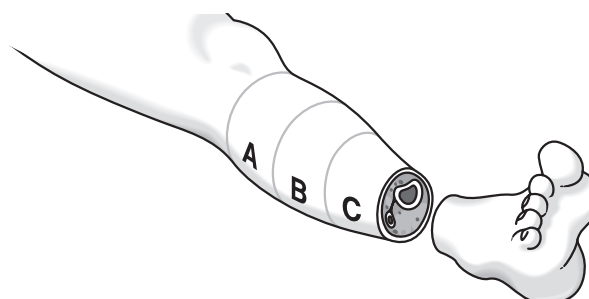

## Techniques

### Pin Insertion

#### Multi-Pin Drill Guide

1. Identify first pin position using Drill Sleeve w/Trocar inserted into Multi-Pin Drill Guide.
  - Dissect down to bone.
  - If using self-drilling pins, insert pin after removing Trocar.
  - If using self-tapping pins, remove Trocar and drill first hole.
    - Disconnect Drill Bit from Universal Cannulated Chuck. (This will maintain Drill Sleeve position, which is especially important when inserting through deep soft tissue.)
2. Identify second pin position and insert appropriate sleeve through Multi-Pin Drill Guide.
  - If using self-drilling pins, insert pin after removing trocar.
  - If using self-tapping pins, remove Trocar and drill second hole.
    - Use depth gauge to determine proper pin length.
    - Insert pin through sleeve.
    - Remove Drill Bit from first hole.
    - Use depth gauge to determine proper pin length.
    - Insert pin.

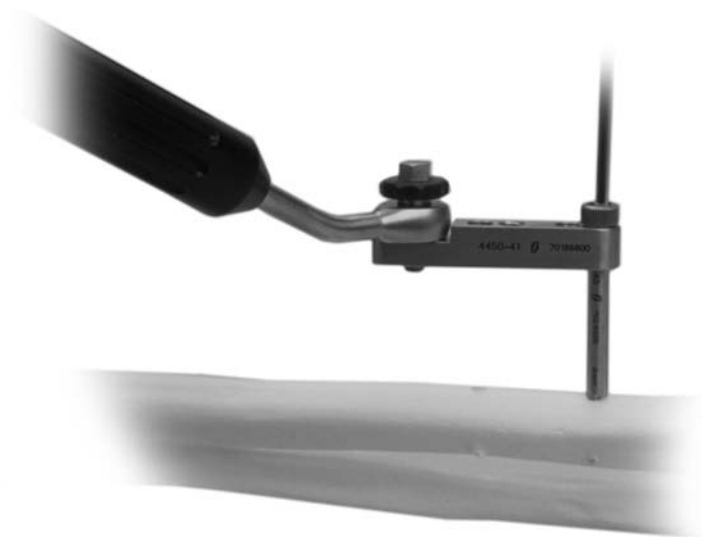

**Multi-Pin Clamp Used as Drill Guide**

1. Insert the first pin through the appropriate sleeve.
  - Place *TransFx* Multi-Pin Clamp onto pin.
2. Insert a sleeve into the second hole of the clamp.
  - Pre-drill or insert a self-drilling pin.



3. Insert a self-tapping pin by hand through the clamp or sleeve.



## Frame Construction

### Unilateral Frame

1. Reduce fracture and stabilize with bone clamps, if possible (once applied, unilateral frames cannot be adjusted to further reduce fracture).

2. Insert most proximal and most distal pins using appropriate Drill Sleeve w/Trocar. In unilateral frames, it is best to make the pins parallel.

- Leave adequate space for insertion of inner pins.



3. Place four adjustable clamps on carbon fiber rod. (If axial compression is not required, *TransFx* Open Pin-to-Rod Clamps may be used.)

- Place end caps on end of rods and apply outer clamps to pins.
- Reduce fracture and tighten end clamps.



4. Insert Drill Sleeves through inner clamps and drill, maintaining safe distance from fracture site.

- Insert final pins and tighten clamps.

**NOTE:** If stacking a frame, the second rod must be connected to end pins prior to drilling inside pins. Drill Sleeve must be passed through both clamps to maintain proper alignment of pins and clamps.

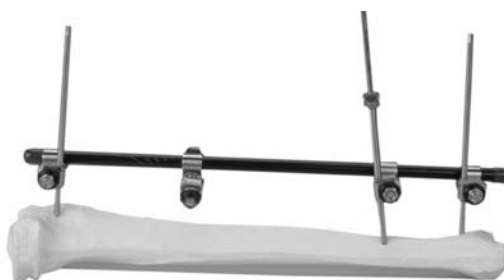

5. For Large Only:  
To compress or distract a unilateral frame, add Open Compressor/  
Distractor as shown.  
**NOTE: One revolution equals  
1mm of compression  
or distraction.**

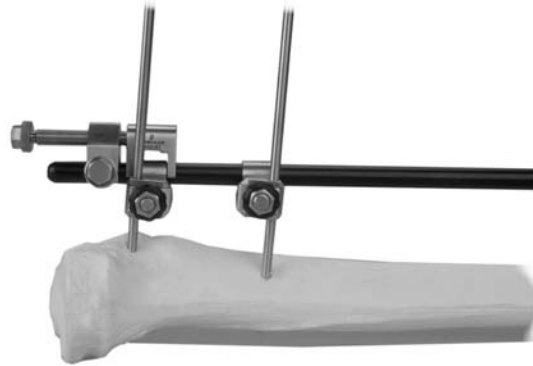

6. To further increase rigidity,  
additional pins with *TransFx*  
Open Pin-to-Rod Clamps may be  
added at any position on the rod.



### Modular Frame

1. Insert two pins in proximal or distal fragment and attach appropriate clamps and rod, creating a fracture unit.
  - Pins may be placed in any plane; however, the pin closest to the fracture should not be so close or angled in such a way that it interferes with the fracture site or causes difficulty in attaching additional connecting rods to the unit.
  - Single-tightening *TransFx* Open Pin-to-Rod Clamps may be used on modular frames.



2. Repeat step one for second fracture unit.



3. Reduce fracture and connect units with appropriate length rods and rod-to-rod clamps.



4. Stacking or reinforcing can be accomplished using inside pins with pin-to-rod clamps and appropriate rod.



### Multi-Pin Modular Frame

1. See multi-pin insertion technique on page 14.
2. Select appropriate *TransFx* Multi-Pin Clamp (side-, end-, or mid-connect).
3. Utilize first multi-pin clamp and then the second on opposite fragment.
4. Connect appropriate rod-to-rod clamps and rod. Then reduce fracture and tighten clamps.



5. Add second rod to increase stability.



### Sample Frames

Lower Extremity

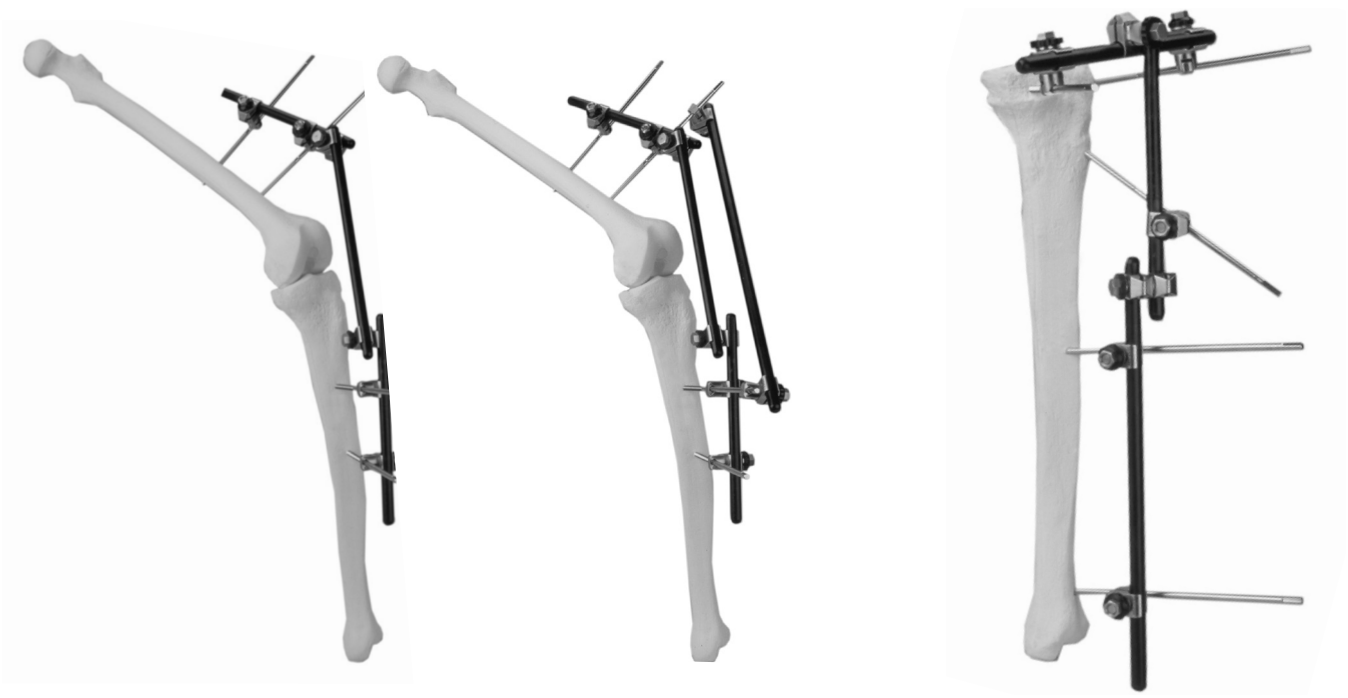

FEMUR/TIBIA (Spanning Frames)

TIBIA (Proximal Tibia)



TIBIA/FOOT (Ankle Spanning Frame)

TIBIA (Angled Rod)

TIBIA/FOOT (11mm with 8mm)



TIBIA/FOOT  
(Multi-Pin Clamps – Spanning Frames)



KNEE FUSION (Triangular)



KNEE FUSION (Parallel)



PELVIS (Resuscitation Frame)



PELVIS (Adjustable Modular Frame Variations)

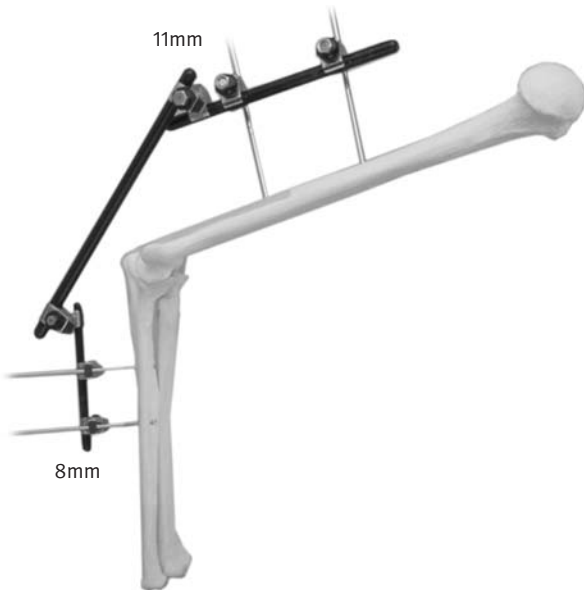

ELBOW (Spanning Frame – 11mm to 8mm)



HUMERUS/HAND (Spanning Frame)

## Postoperative Care

Patient compliance is important to prevent complications at pin sites. Thoroughly instruct the patient or caregiver on how to clean and protect pin sites.



Contact your Zimmer representative or visit us at [www.zimmer.com](http://www.zimmer.com)

The CE mark is valid only if it is also printed on the product label.

