



# Zimmer® Trabecular Metal™ Glenoid

Surgical Technique



Interference fit for secure initial fixation



## Table of Contents

<b>Glenoid Preparation</b>	<b>2</b>
<b>Determining the Size of Trabecular Metal Glenoid</b>	<b>2</b>
Cannulated Preparation	3
Cannulated Guide Placement	3
Insert Central Pin	3
<b>Ream</b>	<b>4</b>
<b>Create Trabecular Metal Slot Opening</b>	<b>5</b>
<b>Glenoid Trial Fit</b>	<b>6</b>
Glenoid Implants/Provisionals Sizing Chart	7
<b>Implantation</b>	<b>8</b>
Option One: Back Side Poly Cementing	8
Option Two: Full Glenoid Vault Cementing	9
Option Three: Non-Cemented (Press-Fit) Application	10
Assessing Trabecular Metal Glenoid Implant Seating	11
<b>Conversion to Bigliani/Flatow Glenoid</b>	<b>12</b>
Extraction of the Trabecular Metal Glenoid using the Extractor Hook	12
Insertion of the Bigliani/Flatow Keeled Poly Glenoid	13

## Glenoid Preparation

Precise placement of the glenoid component is more technically demanding than placement of the humeral component. Before implanting the glenoid component, it is essential to thoroughly evaluate the bony architecture of the glenoid vault. Therefore, it is important to have an axillary radiograph of the glenoid to assess for anterior or posterior wear. If a glenoid radiograph is not possible, a CT or MRI should be obtained.

It is important to identify the center of the glenoid vault. To accomplish this, retract the soft tissues both anteriorly and posteriorly to expose the glenoid. A Fukuda Retractor, or a bent glenoid retractor, should be placed posteriorly. This will subluxate the humerus posteriorly and inferiorly. A special pointed Darrach-type Retractor should be placed anteriorly. Strip the capsule from the articular margin of the glenoid. Place a finger along the anterior glenoid neck to palpate the anteversion of the glenoid face. Tight shoulders may necessitate the release of the capsule along the inferior margin of the glenoid, taking care to avoid injury to the axillary nerve. Release of the posterior capsule, which is often already stretched out from chronic posterior humeral subluxation, is not routinely performed to avoid posterior prosthetic instability. In rare cases of extremely tight shoulders some posterior release may be helpful, but this must be individualized and performed with caution.

Osteophytes may disguise the center of the glenoid vault. The surgeon may choose to trim any marginal osteophytes so the glenoid vault can be clearly defined. Sometimes, osteophytes are more pronounced on one side of the glenoid surface than on the other. In

such cases, the center of the articular surface, including osteophytes, is not the center of the glenoid vault. It is not necessary to remove all the osteophytes to establish the true center of the glenoid vault; however, if any osteophytes are removed, they should be removed carefully. In particular, removal of posterior osteophytes should be done with caution as the capsular attachments may be more proximal resulting in instability.

After removing osteophytes, the center of the humerus can then be centered over the glenoid and the soft tissues balanced. An inadequate or deformed glenoid vault can create a number of technical problems when implanting a glenoid component. Several bone grafting techniques can be used to enhance the bone stock of an inadequate glenoid vault; however, these procedures are very difficult and each one is unique. **If a glenoid replacement is not possible, it is recommended that a hemiarthroplasty be performed instead of a total shoulder replacement. If exposure/glenoid condition does not allow sufficient space for the Straight Driver, it is recommended that the Trabecular Metal™ Glenoid not be used as component alignment with bony preparation is critical.**

## Determining the Size of Trabecular Metal Glenoid

Use the Glenoid Scraper and Glenoid Planer to remove any remaining cartilage and soft tissue from the glenoid. **Use the Glenoid Centering Guides to determine which, if any, glenoid size (black=40mm, white=46mm, and blue=52mm) best fits on the glenoid face (Fig. 1).** The outer dimensions of the guide match the outer dimensions of the glenoid implant.

If there is greatly increased glenoid retroversion noted on the preoperative radiographs or CT scans, a burr may be used to lower the front of the glenoid slightly. The Glenoid Planer is then used to smooth the area. This will help avoid perforating the anterior glenoid wall when drilling perpendicular to a retroverted glenoid face.

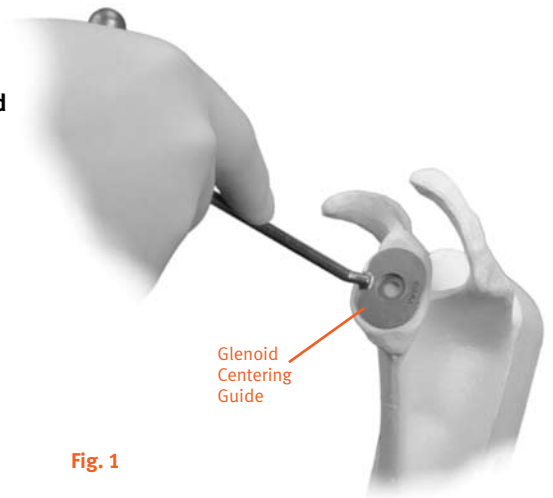

Fig. 1

### Cannulated Preparation

A cannulated technique has been developed with specific instrumentation. This allows the ability to reliably find the center of the glenoid vault. The cannulated reaming technique is written specific to the *Trabecular Metal* Glenoid system but can be utilized with standard *Bigliani/Flatow*® Drill Guides and drills for the keeled or pegged systems.

### Cannulated Guide Placement

To determine the center of the desired glenoid placement, place the Cannulated Drill Guide along the anterior surface of the scapula so that the instrument arm is at 3 o'clock (right) / 9 o'clock (left) and the bushing hole is centered on the glenoid articular surface (Fig. 2).



Fig. 2

The anterior surface of the instrument arm has a channel for holding with the index finger and a sharpened tip to aid positioning. The tip should be placed at the **medial aspect of the glenoid vault** along the transition to the scapula (Fig. 3).

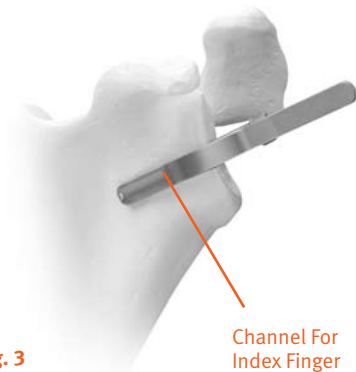

Fig. 3

Channel For Index Finger

### Insert Central Pin

Insert the 2.5mm Drill Bushing into the Cannulated Drill Guide and assess position on the glenoid face (Fig. 4).



Fig. 4

The bushing targets to the tip of the guide and is to be located at the center of glenoid placement.

Load one 2.5mm pin into a pin driver/chuck. Insert the pin through the Drill Bushing and drive (Fig. 5) until the depth mark indicated on the pin meets the top of the Drill Bushing (Fig. 6).

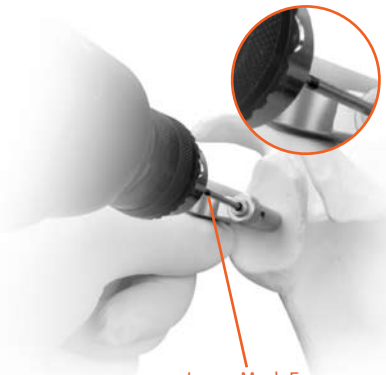

Fig. 5

Laser Mark For Insertion Depth To The Top Of Drill Bushing



Fig. 6

Release the pin from the pin driver/chuck. Remove the Drill Bushing and then the Drill Guide and assess the pin position and alignment on the glenoid face (Fig. 7).

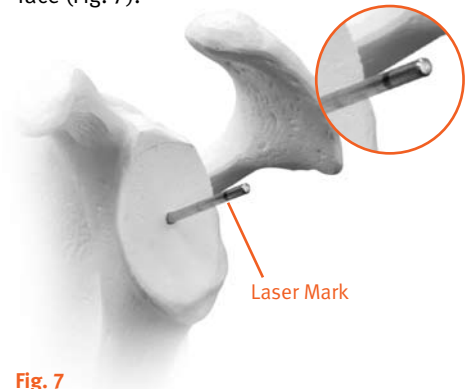

Fig. 7

Laser Mark

**NOTE:** If the position is not correct, the 2.5mm Offset Drill Bushing can be inserted to offset pin placement by 1mm in the anterior/posterior direction (Fig. 8). The small locator pin in the bushing is inserted into the anterior or posterior slot of the drill guide.

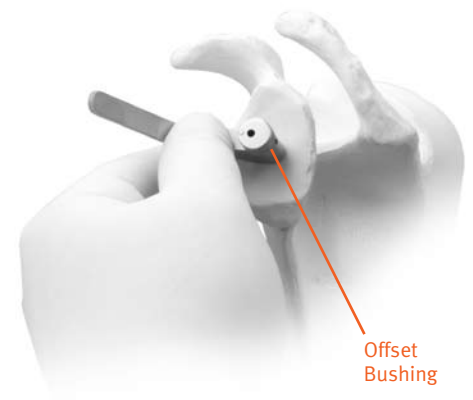

Fig. 8

Offset Bushing

## Ream

Glenoid reaming is performed to achieve intimate contact between the bone and the spherical undersurface of the glenoid implant and establish glenoid version. To help minimize soft tissue damage, **it is recommended to ream the glenoid by hand.** Attach the appropriate size *Trabecular Metal* Glenoid Cannulated Reamer to the Straight Driver (Fig. 9).



Fig. 9

Slip the reamer over the central pin and ream to the desired depth or correction (Fig. 10 and 11).



Fig. 10

**Avoid wobbling the reamer to maintain alignment with the pin axis.** The prepared surface should allow for **full contact along the back side of the *Trabecular Metal* Glenoid** (Fig. 11).



Fig. 11

**If this cannot be achieved due to severe erosion or wear, it is recommended to use a standard *Bigliani/Flatow* keeled or pegged all-poly component.**

**NOTE: Over reaming will reduce the depth of the glenoid vault and should be avoided. It is important to not remove too much subcortical bone as this may affect glenoid stability.**

Remove the reamer.

## Create Trabecular Metal Slot Opening

With the 2.5mm pin in place, use the 6mm Cannulated Drill (Fig. 12) to create a pilot hole for the drill guide that will create the superior and inferior holes.



Fig. 12

To do this, attach the 6mm Cannulated Drill to the Cannulated Straight Driver by sliding the Driver tabs into rounded slots of the 6mm Cannulated Drill. Turn the Cannulated Straight Driver to retain the 6mm Cannulated Drill. Place the Cannulated Drill assembly over the 2.5mm Pin and drill until the housing collar is flush to the glenoid face (Fig. 13). The 6mm Cannulated Drill and the 2.5mm pin are now removed.



Fig. 13

To prepare the superior and inferior holes, attach the *Trabecular Metal Glenoid 6mm Drill* (non-cannulated) to the Straight Driver (Fig. 14). Preparation of the superior and inferior holes is accomplished by inserting the appropriate size *Trabecular Metal Glenoid Drill Guide* into the prepared 6mm hole and aligning it to the glenoid face. Drill the inferior hole first. (Fig. 15).



Fig. 14

The 2.5mm Drill Bushing or another *Trabecular Metal Glenoid 6mm Drill* should be used as an Anti-rotation pin to maintain alignment of the guide while the third hole (superior) is drilled (Fig. 16). Next, remove the *Trabecular Metal Glenoid Drill Guide*.



Fig. 15



Fig. 16

Next, use the same size *Trabecular Metal Glenoid A/P Drill Guide* to drill the anterior and posterior holes (Fig. 17).

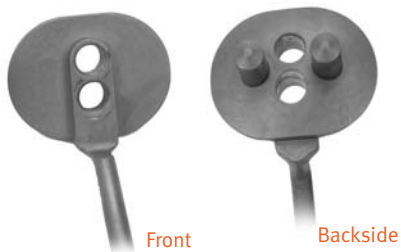

Fig. 17

Place the appropriate *Trabecular Metal Glenoid A/P Drill Guide* into the prepared superior and inferior holes created by the *Trabecular Metal Glenoid Drill Guide*. If necessary, apply thumb pressure to the *Trabecular Metal Glenoid A/P Drill Guide* to ensure it seats flush against the reamed glenoid bone. Insert the same 6mm drill (non-cannulated) into the posterior hole of the *Trabecular Metal A/P Drill Guide* and drill the posterior hole until the 6mm drill is flush with the guide (Fig.18).



Fig. 18

While making an effort to not rotate the *Trabecular Metal Glenoid A/P Drill Guide*, repeat the same steps for the anterior hole. Next, remove the *Trabecular Metal A/P Drill Guide*.

**Note: If the *Trabecular Metal Glenoid A/P Drill Guide* doesn't insert or sit properly, verify that the drill guide is the correct size (i.e. same size of the drill guide used to create the superior and inferior holes.)**

### Create Trabecular Metal Slot Opening

**WARNING: The use of the *Trabecular Metal Glenoid Chisel* requires that it is oriented superiorly and inferiorly only.**

Use the *Trabecular Metal Glenoid Chisel* to remove the remaining bone in the slot (Fig. 19). Place the round tip into the middle hole, aligning the long axis of the chisel with the three drill holes (Fig. 20). Impact with a mallet until fully seated (Fig. 21).



Fig. 19



Fig. 20



Fig. 21

This will help ensure an appropriate internal depth and width to accept the distal portion of the glenoid component. This step should be implemented with caution if the bone is soft or deficient.

### Glenoid Trial Fit

Insert the appropriate size solid color *Trabecular Metal Glenoid Provisional* into the keel opening with the *Glenoid Inserter* (Fig. 22).



Fig. 22









The solid color provisionals are used when the prepared surface of the glenoid matches the prepared surface of the humerus.

As they are accomplished separately, there may be times when the prepared articular surface of the glenoid does not match the articular surface of the desired humeral head. When this occurs, the bi-colored (mismatch) provisionals must be used. This is necessary to match the articular surfaces of the selected components.

### Glenoid Implants/Provisionals Sizing Chart

Peripheral color corresponds to prepared glenoid size. Center bar color, of bi-colored provisional, corresponds to humeral head size.

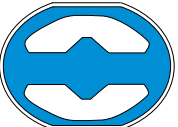
### Glenoid Implants/Provisional Sizing Chart

		Humeral Head Sizes			
		40mm	46mm	52mm	56mm
Instrumentation Colors	Black	 BK/40	 BK/46		
	White	 WH/40	 WH/46	 WH/52	
	Blue		 BL/46	 BL/52	 BL/56

The color of the center bar of the *Trabecular Metal Glenoid Provisional* must always match the color of the *Humeral Head Provisional*.

The chart above illustrates the range of glenoid sizes.

For example, if white (46mm) instrumentation was used to size/prepare the glenoid, either a black (40mm), white (46mm) or blue (52mm) Humeral Head may be used. Continuing, if a blue Humeral Head is selected, remove the white WH/46 Glenoid Provisional and replace it with the WH/52 white with blue center bar Glenoid Provisional.

The solid color glenoid provisional should be replaced with the appropriate bi-colored provisional for joint reduction and trial range of motion. Remove the Provisional Head, but leave the Stem Provisional in place to help decrease bleeding while implanting the glenoid component.

The base of the Glenoid Provisional should not overhang the perimeter of the glenoid. The undersurface of the provisional should seat flush with the reamed surface of the bone. Loosening, component failure or excessive wear may occur if the glenoid component lacks sufficient bony support.

**NOTE: If the fit of the glenoid provisional is not appropriate, it may be necessary to reassess reaming and the depth of the slot. If additional glenoid reaming is necessary to improve the glenoid fit, attach the appropriate size *Trabecular Metal Pegged Glenoid Reamer* (Fig. 23) to the Straight Driver and use the T-handle to ream the glenoid. Consideration must also be given to re-drilling and the additional use of the chisel to ensure that the provisional does not bottom out in the glenoid.**



**Fig. 23** *Trabecular Metal Pegged Glenoid Reamer*

**Avoid wobbling the reamer or changing the version set previously.**

**CAUTION: Recheck the hole depths to verify that they are sufficient to assure that the undersurface of the implant will seat flush with the reamed surface of the bone. Failure to verify this may lead to loosening, component failure or excessive wear of the implant.**

**If the provisional cannot seat completely on the reamed surface, the preparation should be converted to a *Bigliani/Flatow Keeled Glenoid Component*.**

## Implantation

Implantation Option	Clearance
Option 1: Back Side Poly Cementing	Worldwide Clearance
Option 2: Full Glenoid Vault Cementing	Worldwide Clearance
Option 3: Non-Cemented (Press-Fit) Application	Outside the U.S. ONLY. Not cleared for non-cemented use in the United States.

### Option One: Back Side Poly Cementing

(APPROVED FOR USE IN THE U.S. AND OUTSIDE THE U.S.)

Remove the *Trabecular Metal* Glenoid Provisional and use pulsatile lavage, such as the *Pulsavac*® Wound Debridement System, to irrigate the glenoid vault. Coagulate any active bleeding, and dry the glenoid vault. Insert a thrombin-soaked Keel Sponge to dry the vault. Remove the Keel Sponge. Prior to opening the glenoid implant, confirm that the component matches the glenoid provisional used in the trial reduction.

Apply the *Trabecular Metal* Glenoid implant to the appropriate size *Trabecular Metal* Glenoid Inserter by sliding the A/P tabs of the inserter over the A/P edges of the component (Fig. 24).

**Note: The inserter will loosely retain the implant between the A/P tabs. By design, the S/I tabs are not meant to retain the implant to the inserter.**



Fig. 24

Apply cement to the back side surface, covering the poly portion only, of the *Trabecular Metal* Glenoid implant in an even distribution (Fig. 25). Do not apply cement into any of the keel holes or on the *Trabecular Metal* keel itself.

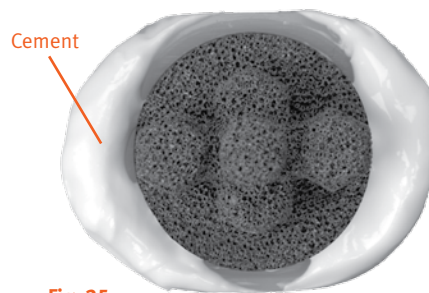

Fig. 25

Insert the *Trabecular Metal* Glenoid Inserter straight-on, directly into the glenoid vault and impact with a mallet until there is complete contact by the implant with the perimeter of the glenoid (Fig. 26).



Fig. 26

Care should be taken to maintain pressure on the glenoid with the instrument until the cement has hardened. Carefully remove the inserter by toggling the inserter **anteriorly** to release the tabs (Fig. 27). Remove excess cement with care.



Fig. 27

**NOTE: It is critical that the implant keel is inserted in alignment with the bone preparation so that full contact is assured (Fig. 28). Do not force the implant into a different orientation.**

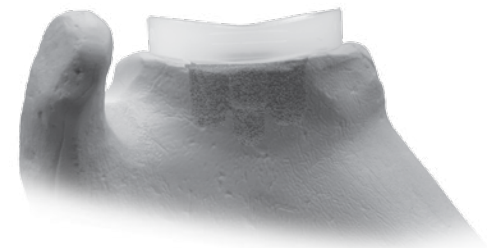

Fig. 28

### Option Two: Full Glenoid Vault Cementing

(APPROVED FOR USE IN U.S. AND  
OUTSIDE THE U.S.)

Remove the *Trabecular Metal* Glenoid Provisional and use pulsatile lavage, such as the *Pulsavac* Wound Debridement System, to irrigate the glenoid vault. Coagulate any active bleeding, and dry the glenoid vault. Insert a thrombin-soaked Keel Sponge to dry the vault. Remove the Keel Sponge.

Introduce cement into the keel slot using a 60cc syringe. Cement should be introduced early in the working time to facilitate pressurization into the cancellous bone bed.

Prior to opening the glenoid implant, confirm that the component matches the glenoid provisional used in the trial reduction. Apply the *Trabecular Metal* Glenoid implant to the appropriate size *Trabecular Metal* Glenoid Inserter by sliding the A/P tabs of the inserter over the A/P edges of the component (Fig. 29).

**Note: The inserter will loosely retain the implant between the A/P tabs. By design, the S/I tabs are not meant to retain the implant to the inserter.**

**Apply cement to the back side surface of the *Trabecular Metal* Glenoid implant.**

Insert the *Trabecular Metal* Glenoid Inserter straight-on, directly into the glenoid vault and impact with a mallet until there is complete contact by the implant with the perimeter of the glenoid (Fig. 30).



Fig. 29



Fig. 30

**NOTE: It is critical that the implant keel is inserted in alignment with the bone preparation so that full contact is assured.**

Do not force the implant into a different orientation. Care should be taken to maintain pressure on the glenoid with the instrument until the cement has hardened. Carefully remove the inserter by toggling the inserter **anteriorly** to release the tabs (Fig. 31). Remove excess cement with care.

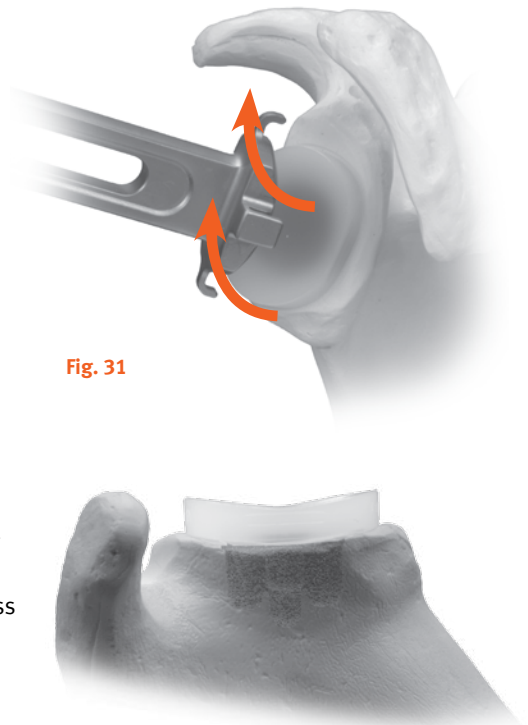

Fig. 31

## Option Three:

**Non-Cemented (Press Fit)****Application** (OUTSIDE THE U.S. ONLY)

**NOTE: The use of this implant is NOT cleared for non-cemented use in the United States.**

Remove the *Trabecular Metal* Glenoid Provisional and use a pulsatile lavage, such as the *Pulsavac* Wound Debridement System, to irrigate the glenoid vault. Coagulate any active bleeding, and dry the glenoid vault. Insert a thrombin-soaked Keel Sponge to dry the vault. Remove the Keel Sponge.

Prior to opening the glenoid implant, confirm that the component matches the glenoid provisional size used in the trial reduction. Apply the *Trabecular Metal* Glenoid implant to the appropriate size *Trabecular Metal* Glenoid Inserter by sliding the tabs of the inserter over the edges of the component (Fig. 32). Insert the *Trabecular Metal* Glenoid Inserter straight on directly into the glenoid vault and impact with a mallet until there is complete contact by the implant with the perimeter of the glenoid (Fig. 33).

Carefully remove the inserter by toggling the inserter **anteriorly** to release the tabs (Fig. 34).

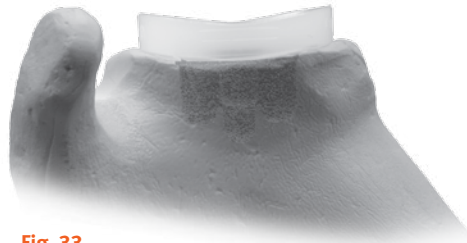

**Fig. 33**

**NOTE: It is critical that the implant keel is inserted in alignment with the bone preparation so that complete contact is assured. Do not force the implant into a different orientation.**

Make sure the implant is completely seated on the articular surface. **For press-fit implantation of the *Trabecular Metal* Glenoid, the bone must be of sufficient quality and strength to provide initial stability.**

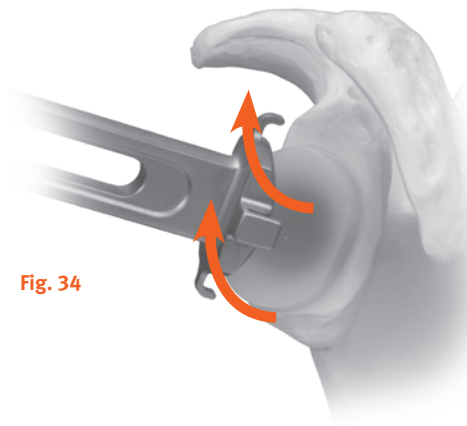

**Fig. 34**



**Fig. 32**

### Assessing Trabecular Metal Glenoid Implant Seating

During and immediately after impaction of the *Trabecular Metal* Glenoid, the stability of the device should be assessed. The *Trabecular Metal* Glenoid must be initially stable for biologic fixation to occur.

Upon immediate impaction, use of the *Trabecular Metal* Check Gauge (Fig. 35) can aid in assessing if there are any significant gaps between the articular surface and the back side of the poly portion of the implant.

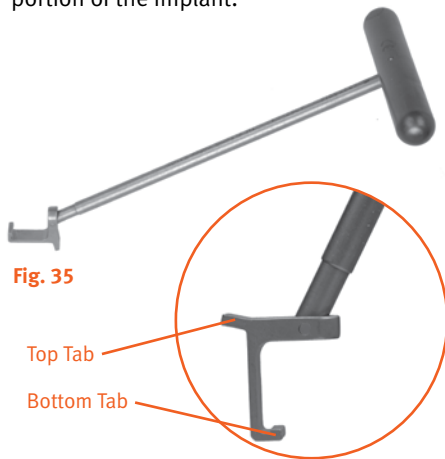

Fig. 35

Top Tab

Bottom Tab

A significant gap is defined as a gap greater than (>) 1.5mm at any point around the implant. To assess any posterior, inferior, and superior gaps, take the *Trabecular Metal* Glenoid Check Gauge and position it so that the bottom tab is inserted against the bone/implant poly interface of the implant posteriorly, inferiorly, or superiorly (Fig. 36). If the bottom tab is able to slide under the bone/implant poly interface, there is a gap greater than 1.5mm. If the bottom tab is not able to slide under the bone/implant poly interface, there is less than or equal to a 1.5mm gap.

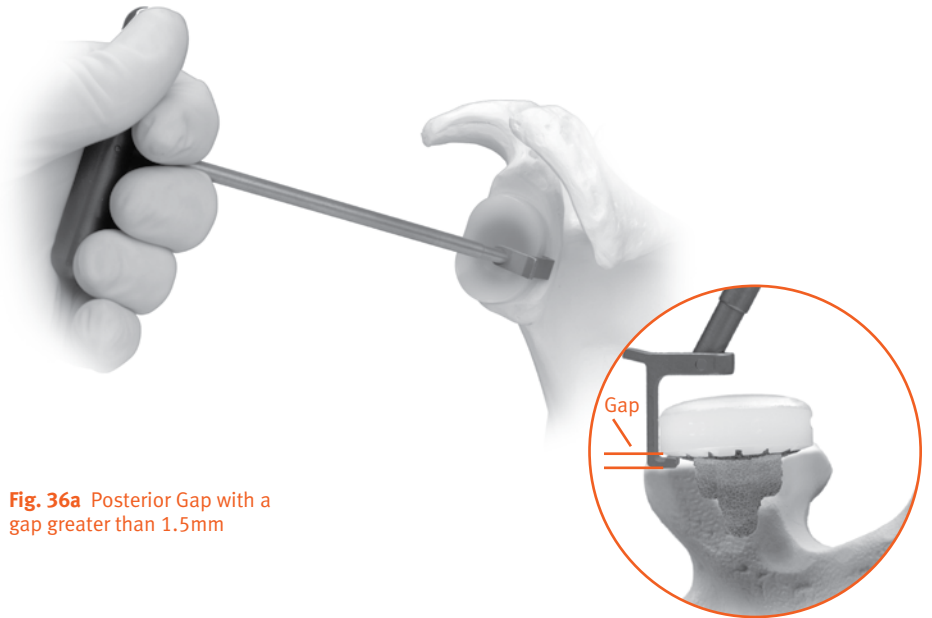

Fig. 36a Posterior Gap with a gap greater than 1.5mm



Fig. 36b Inferior Gap with a gap greater than 1.5mm

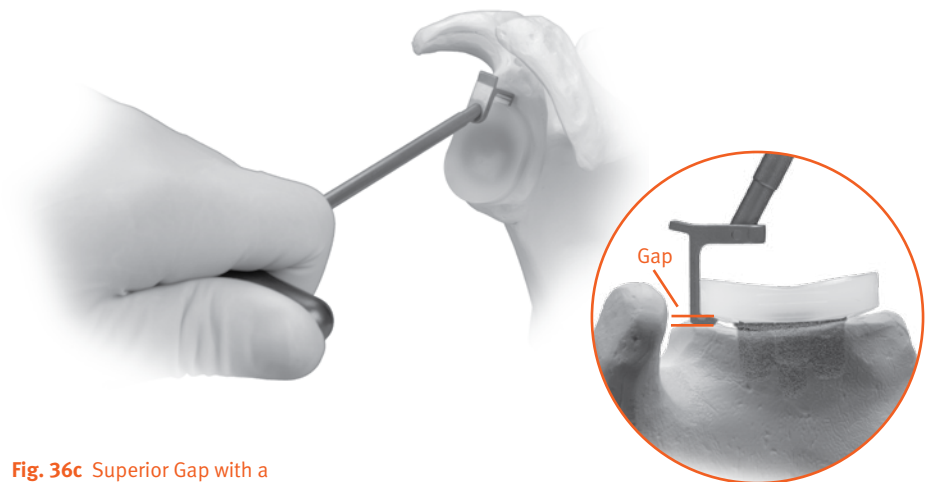

Fig. 36c Superior Gap with a gap greater than 1.5mm

To assess any anterior gaps, take the *Trabecular Metal* Glenoid Check Gauge and position it so that the top tab is inserted against the bone/implant poly interface of the implant anteriorly. If the top tab is able to slide under the bone/implant poly interface, there is a gap greater than 1.5mm. If the top tab is not able to slide under the bone/implant poly interface, there is less than or equal to a 1.5mm gap.

If it is determined that there are no gaps greater than 1.5mm between the bone/implant poly interface at any point around the implant and the implant is not misaligned or malpositioned, then implant is considered to be successfully positioned. If it is determined that there are area(s) in which a gap exists that is greater than 1.5mm, then reattach the inserter and use 2 to 3 firm blows to see if the gap can be closed to less than 1.5mm according to the Check Gauge.

If the gap cannot be closed or the implant is misaligned or malpositioned, then remove the implant with the *Trabecular Metal* Glenoid Extractor Hook and insert a keeled poly glenoid implant.

**NOTE: If the gap appears at only one section and is seated elsewhere, caution should be taken with any additional blows to avoid damaging the glenoid bone. If in doubt, remove the implant as described.**

Please refer to the following for full instructions on extracting the implant and use of a *Bigliani/Flatow* Keeled Poly Glenoid.

### Extraction of the Trabecular Metal Glenoid using the Extractor Hook

Approaching inferiorly to superiorly, apply the *Trabecular Metal* Glenoid Extractor Hook for removal of the implant (Figs. 37, 38 & 39). If additional force is required, attach, via the threads, the *Bigliani/Flatow* Inserter/Extractor to the handle of the *Trabecular Metal* Glenoid Extractor Hook and use the Slaphammer. **DO NOT REUSE THE IMPLANT ONCE IT HAS BEEN REMOVED.**

Upon extracting the *Trabecular Metal* Glenoid Implant, proceed to implant a keeled poly glenoid implant.

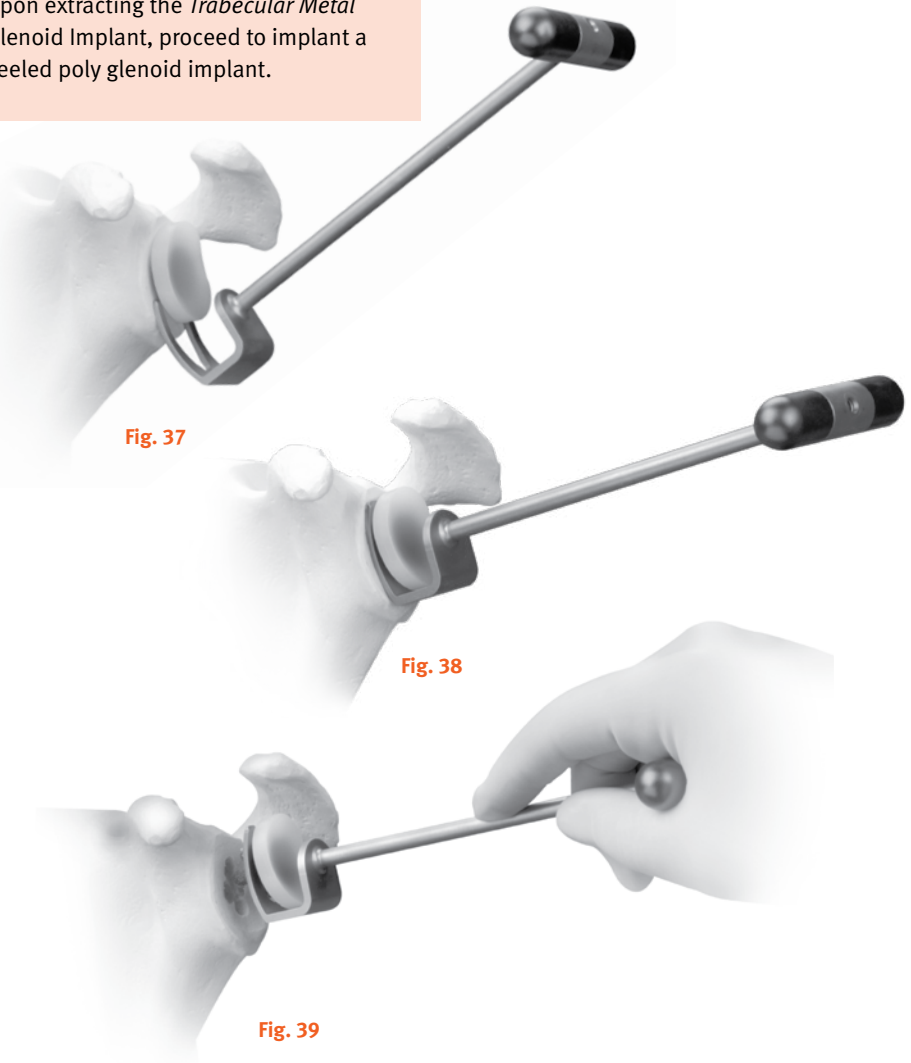

## Insertion of the Bigliani/ Flatow Keeled Poly Glenoid

(See Bigliani/Flatow Total  
Shoulder System)

After extracting the *Trabecular Metal* Glenoid implant, proceed to implant a standard keeled poly glenoid. Use pulsatile lavage, such as the *Pulsavac* Wound Debridement System, to irrigate the glenoid vault. Coagulate any active bleeding, dry the glenoid vault, and insert a thrombin-soaked Keel Sponge to dry the vault (Fig. 40). Remove the Keel Sponge. Introduce cement into the keel slot using a 60cc syringe, being careful that no cement is applied to the articular surface of the glenoid bone. Cement should be introduced early in the working time to facilitate pressurization into the cancellous bone bed. Then attach a Pressurizer Sponge to the appropriate Glenoid Sizer/Pressurizer (Fig. 41) and pressurize the cement. When the Glenoid Sizer/Pressurizer is removed, some of the cement may adhere to the instrument and the sponge; however, most of the cement remains in the glenoid having been pressurized into the cancellous bone. Apply additional cement and repressurize. Finally, apply more cement before inserting the glenoid component. If desired, you may apply cement to the keel. Do not apply cement to the underside of the glenoid component. Prior to opening the keeled glenoid implant, confirm that the component matches the size of the *Trabecular Metal* Glenoid implant used.

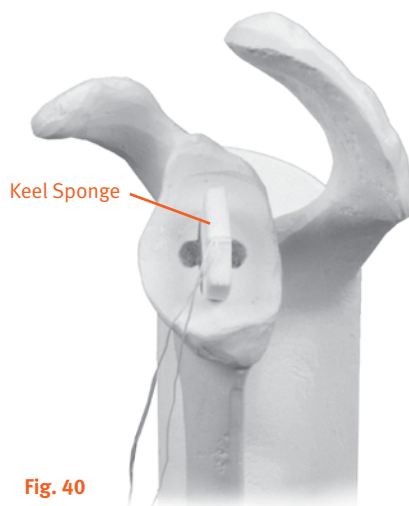

Fig. 40



Fig. 41

Keeled Glenoid  
Sizer/Pressurizer

Use the Glenoid Inserter (out of the *Bigliani/Flatow* Total Shoulder System) to insert the component (Fig. 42). Then use the Glenoid Pusher to impact the component until there is complete contact with the perimeter of the glenoid (Fig. 43). Maintain pressure on the glenoid with the pusher or thumb until the cement has hardened. Be sure that the pressure remains centralized within the glenoid so that eccentric pressure is not applied during cement hardening. Remove excess cement with care.



Fig. 42

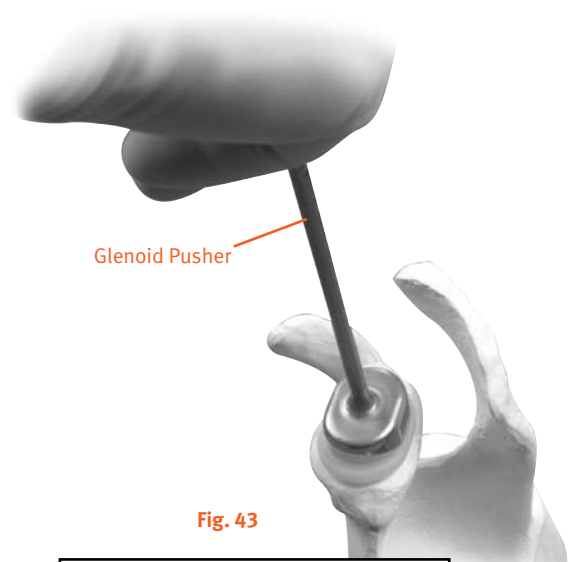
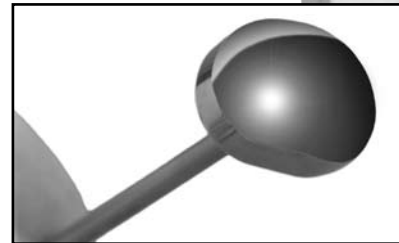

Fig. 43









Please refer to package insert for complete product information, including contraindications, warnings, precautions, and adverse effects.



Contact your Zimmer representative or visit us at [www.zimmer.com](http://www.zimmer.com)



+H124974301204001/\$090811R1H09X