



**M/DN[®] MIS
Intramedullary
Femoral Fixation
Surgical
Technique**



Surgical Techniques for MIS Fixation of Femoral Fractures with an M/DN Nail

Table of Contents

Introduction	2
Guide Design	2
Indications	3
Surgical Technique	4
Preoperative Planning	4
Patient Positioning	4
Reduction	5
Radiographic Control	5
Prep and Drape	5
Starting Point and Steinmann Pin Insertion and Incision Using Long Cannulated Awl	6
Incision	6
Creating the Entry Portal	6
Optional Technique: Starting Point and Steinmann Pin Insertion	7
Incision	7
Proximal Reaming	8
Femoral Reaming	10
Guide and Nail Preparation	12
Interlocking Application	13
Recon Application	13
Nail Insertion	14
Proximal Locking (For Interlocking Application)	15
Proximal Locking (For Recon Application)	17
Nail Cap Placement	20
Distal Interlocking	20
Incision Closure	22
Extraction	22
Instrument Case	23

Introduction

Closed intramedullary nailing has long been a common method of treating noncomminuted fractures of the femur and tibia. The interlocking nail has extended the indications of closed intramedullary nailing to include comminuted fractures, fractures with bone loss, and proximal and distal fractures of the femur, tibia, and humerus. The interlocking technique offers the advantages of: 1) a closed intramedullary nailing technique; 2) small incisions away from the fracture site; 3) reduced risk of infection; and 4) decreased risk of shortening or rotation.

The *M/DN* Intramedullary Fixation System is designed to further extend the indications for intramedullary nailing. Specific features of the various *M/DN* Nails allow for their use in both metaphyseal and diaphyseal fractures. The surgeon can now capture fractures closer to the joint.

The *Zimmer® Minimally Invasive Solutions™* (MIS) approach uses a smaller (usually less than 2cm) incision for the entry portal, reaming and nail insertion. The MIS approach is also more proximal than the standard surgical approach, which allows for easier access to the medullary canal. This more proximal and direct approach uses fluoroscopy instead of standard palpation to determine the correct entry point.

Guide Design

This proximal approach dictates that the main targeting instruments be designed with longer lengths than the standard interlocking instruments to accommodate the more proximal starting point. The dimensions of the *M/DN* MIS Targeting Guide are 21cm long and 8.5cm wide to accommodate this minimally invasive technique.

The MIS Targeting Guide utilizes a normal *M/DN* Femoral Fixation connection/attachment. This Guide can be used for Proximal Oblique interlocking and Cephalomedullary interlocking procedures.

Indications

The *M/DN* Femoral Nail is indicated for use in a variety of femoral fractures (Fig. 1), such as:

- A. Comminuted fractures
- B. Segmental fractures
- C. Fractures with bone loss
- D. Proximal and distal fractures
- E. Nonunions
- F. Subtrochanteric fractures
- G. Intertrochanteric fractures

Fig. 1

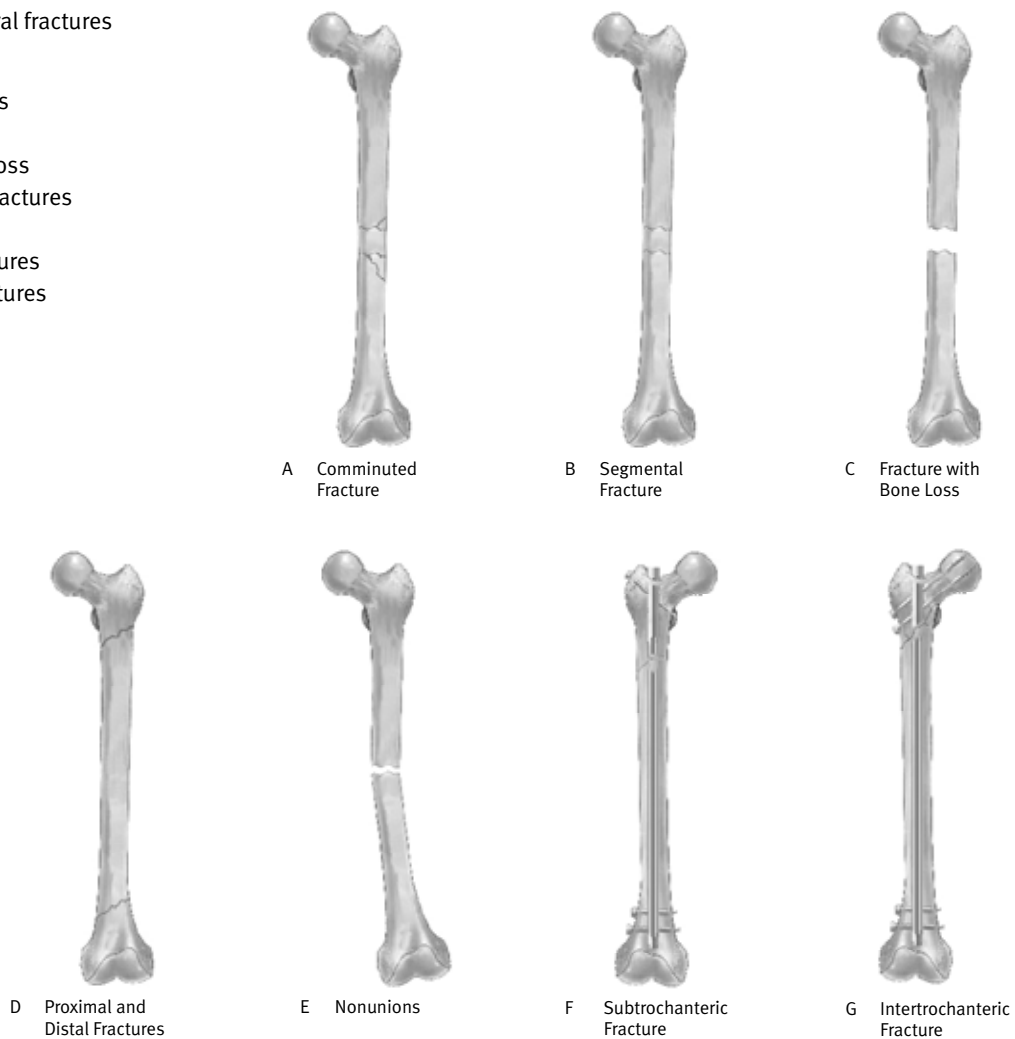

Surgical Technique

(Interlocking and Recon Applications)

The *M/DN* Femoral Nail is designed for varied use. A single nail can be used for both right and left standard interlocking or recon procedures. The femoral nail is available in the most commonly used sizes. These nails range in diameters from 8mm to 16mm and lengths from 24cm to 50cm.

Preoperative Planning

Proper preoperative planning is essential to successful interlocking or recon nailing of the femur. To determine the appropriate nail size, an ossimeter, roentgenogram templates, and an x-ray film of the unaffected extremity are necessary for determining canal size at the isthmus and for measuring the length of the femur to aid in determining nail length.

The Nail Length Gauge or Harris/Galante Bulb-Tip (Sounds), available in diameters from 10mm-17mm, can be used as an alternate techniques to determine nail diameter and length.

X-rays taken at a 36-inch distance from the x-ray source result in 10-15 percent magnification of bone. The ossimeter has both an actual size scale and one that takes into account this magnification. It should be used routinely to determine nail diameter and length.

The proper length of nail should extend from the tip of the greater trochanter to the epiphyseal scar. The diameter of the femoral nail should match the isthmus in the lateral x-ray projection.

The surgeon should review the x-ray to assure that there are no unusual anatomic variations.

Patient Positioning

The patient may be placed in either the supine (free legged or traction) or lateral (traction) position.

(1) SUPINE FREE LEGGED – Place the patient supine on a radiolucent table (Fig. 2). The table should not have a central pole or metal sidebars. Place the patient's buttock next to the edge of the table with a bump under the buttock. The eccentric position and elevated buttock improves starting site position and reduces drape encroachment. The ipsilateral upper trunk and extremity should angle towards the contralateral shoulder. The ipsilateral arm should be placed above the chest on an arm holder or on a pillow with stockinet.



Fig. 2

(2) SUPINE TRACTION ON FRACTURE TABLE – Place the patient supine on the fracture table (Fig. 3). Pad all areas of potential pressure. Flex and abduct the non-injured leg onto a well padded leg holder. Or, place the non-injured leg into a scissor type position.

Position the buttock of the injured leg as close to the edge of the table as possible. Some tables will allow for an eccentric peroneal post connection to the table. Make sure the peroneal post is padded and wide in order to dissipate the pressure on the groin area.

Place the injured leg into skeletal traction (distal femoral or proximal tibial) or foot skin traction. The ipsilateral arm should be placed above the chest on an arm holder or on a pillow with stockinet.

(3) LATERAL TRACTION ON FRACTURE TABLE – Use the radiolucent table with a radiolucent peroneal post. Place the traction boots on the patient during anesthesia induction. Turn the patient in a lateral position, with the operative leg over the top of the peroneal post. Attach the boots to the table with straight traction applied through the boots.

If heavy traction is necessary, a pin is placed in the distal femur and the knee is flexed, applying traction through the pin. Flex and adduct the operative leg. Straighten the non-operative leg in line with the body. Rotate the patella slightly inwards towards the floor, to help prevent an external rotation deformity. Bring the C-arm in perpendicular to the long axis of the femur. When moving proximally and distally, the entire C-arm is moved, to stay perpendicular to the long axis. To visualize the proximal femur and the head, rotate the C-arm 15° over the top and tilted 45° cephalad.



Fig. 3

Reduction

It is important to reduce the fracture before beginning the surgical procedure.

Radiographic Control

NOTE: It is essential to obtain excellent A/P and lateral images of the femoral head and neck prior to beginning the surgery regardless of which patient position is used.

The use of image intensification or other x-ray imaging is required. The image intensifier should be sterile-draped and may be positioned from either the contralateral or ipsilateral side of the operating table.

Confirm visualization of the hip as well as the shaft of the femur using image intensification before prepping and draping. Bend the patient's torso away from the affected extremity to improve access to the greater trochanter. If access to the greater trochanter is still inadequate, adduct the affected leg. However, to achieve proper alignment of the fracture, this adducted position must be corrected prior to insertion of the nail.

Prep and Drape

The prep includes the ipsilateral axilla, trunk, buttock, hip, thigh (circumferentially), and knee. The drape should extend up to the axilla with U-shaped drapes. The free trunk and buttock skin improves nail insertion and diminishes guide entrapment on the drapes. Furthermore, the free area increases the freedom for percutaneous insertion and incision closure. The drape should extend past the knee to allow for distal interlock insertion.

Starting Point and Steinmann Pin Insertion and Incision Using Long Cannulated Awl

Palpate the line of the femur starting at the greater trochanter. Continue this line of insertion proximally until reaching the level approximating the anterior superior iliac spine (Fig. 4). (Using a sterile marking pen, mark the line of intersection between these two lines; this corresponds to the insertion site.) Insert the Long Cannulated Awl percutaneously. The correct line of insertion is determined by the tactile sensation of the Awl and by the C-arm imaging.



Fig. 4

Incision

Use a small blade to create an incision centered below the iliac spine. The incision needs to be only 15mm- 20mm in width.

Creating the Entry Portal

Locating the correct entry portal in the piriformis fossa is extremely important. For the interlocking procedure, place the Long Cannulated Awl at the piriformis fossa (Fig. 5A) and check its position with A/P and lateral views.



Fig. 5A

For the recon procedure, place the Long Cannulated Awl in the anterior portion of the piriformis fossa approximately 5mm anterior to the position you would choose when doing a standard femoral nailing (Fig. 5B). This will facilitate screw placement in the center of the femoral neck.

Check the position of the awl with both A/P and lateral images before creating the portal. On the A/P image, the awl should lie at the base of the femoral neck adjacent to the greater trochanter. On the lateral view, it should be oriented just posterior to the center of the femoral neck.

When the correct position is achieved, rotate the Awl to create the entry portal for the Ball-Tip Guide Wire.

If using the Long Cannulated Awl, the 3.0mm Ball-Tip Guide Wire can be inserted through the Awl.

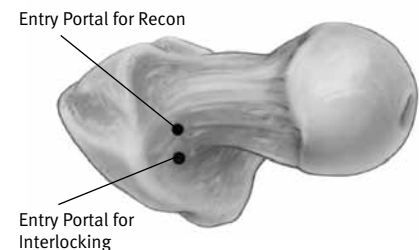

Fig. 5B

Optional Technique: Starting Point and Steinmann Pin Insertion

Palpate the line of the femur starting at the greater trochanter. Continue this line of insertion proximally until reaching the level approximating the anterior superior iliac spine (Fig. 6). (Using a sterile marking pen, the line of intersection between these two lines corresponds to the insertion site.) Insert the 14.0 inch Steinmann Pin percutaneously. The correct line of insertion is determined by the tactile sensation of the pin and by the C-arm imaging (Fig. 7).



Fig. 6



Fig. 7

Insert the pin with small movements to reduce the risk of errant pin injury. Once reaching the site of insertion corresponding to the piriformis fossa, confirm the entry site with C-arm bi-planar fluoroscopy. Since the insertion technique is percutaneous, the site is not determined by direct digital palpation. The correct site is confirmed by tactile sensation through the pin and by fluoroscopic imaging. The correct site of insertion for reconstruction nailing is approximately 5mm-8mm anterior to the piriformis fossa.

This positional change will facilitate cephalo-medullary screw placement. If the starting site is too posterior, reaming and nail placement may violate the posterior cortical entry and reduce subsequent proximal canal stability. If the starting point is too anterior, increased hoop stresses upon nail insertion may fracture the anterior cortex. Once the correct position is confirmed, place the pin well into the proximal femur to about the level of the lesser trochanter. By evaluating the position with fluoroscopy, the line of insertion should place the pin into the center of the canal (Fig. 8).

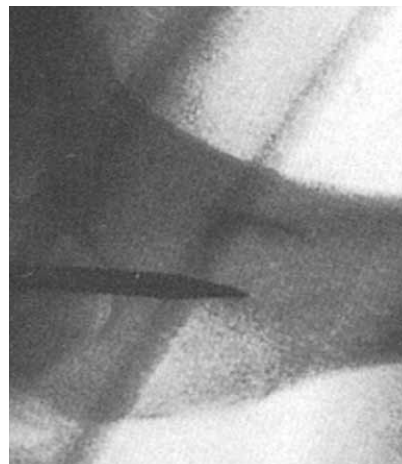

Fig. 8

Incision

Use a small blade (#15) to create an incision centered over the guide pin. The incision needs to be only 15mm-20mm in width. Make sure the guide pin is freely mobile in all directions. If the guide pin is not mobile, the dermis or subcutaneous tissue is still attached to the guide pin. Using the guide pin as a directional guide, the incision must then be made deeper. Once the pin is freely mobile and placed to the level of the lesser trochanter, the rigid proximal reaming may begin (Fig. 9 & 10).



Fig. 9



Fig. 10

Proximal Reaming

Place the Percutaneous Centering Bushing through the Cannula (Fig. 11). Insert the Cannula over the Guide Pin and into the incision, seating the Cannula firmly onto the trochanteric bone (Fig. 12). Remove the Centering Bushing, leaving the guide pin in place. Place the cannulated Percutaneous Trochanteric Reamer over the Steinmann Pin (Fig. 13).



Fig. 11

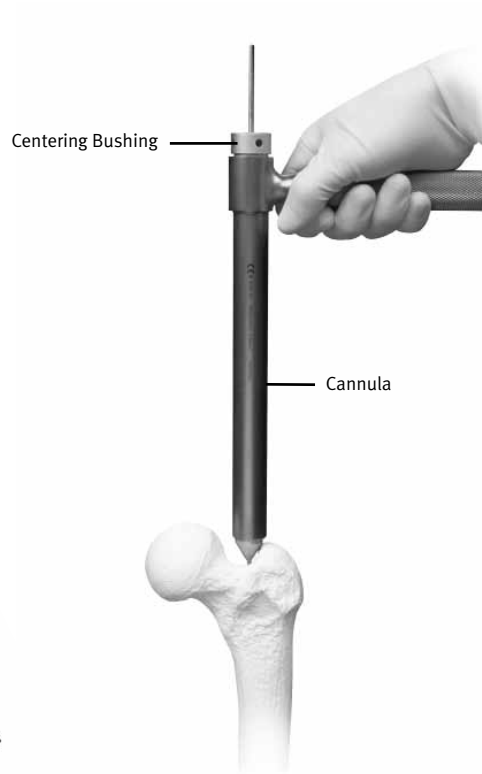

Fig. 12



Fig. 13

Then insert the reamer over the pin down to the trochanteric area (Fig. 14 & 15). Make sure the reamer moves freely over the pin. If the reamer does not move freely, eccentric reaming may erode through the pin or create an errant reaming tract. Reaming must be completed to the level of the lesser trochanter in order to assist in Ball-Tip Guide Wire Insertion.

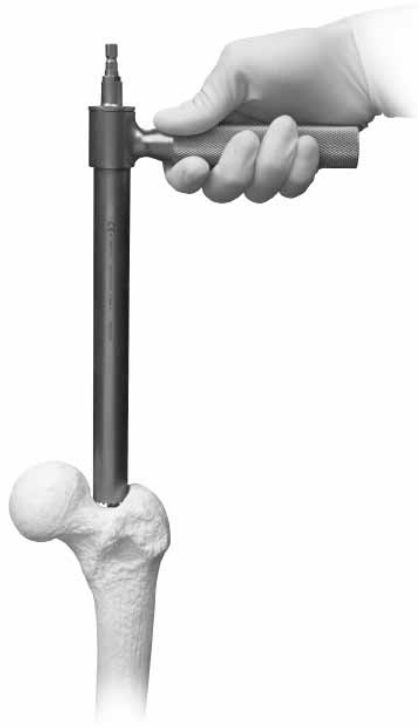

Fig. 14



Fig. 15

If necessary, use the Percutaneous Trochanteric reamer to expand the canal in the area of the trochanter (Fig. 16). Proceed with caution as overuse of this reamer could cause the trochanteric bone to fracture.

Femoral Reaming

Conventional Guide Wire/ Exchange Tube Technique

Remove the Guide Pin and insert the Ball-Tip Guide Wire through the piriformis fossa into the proximal aspect of the femur. The Ball-Tip Guide Wire may also be described as a Bulb-Tip or Bullet-Tip Guide Wire. The proximal femur and/or the femoral diaphyseal fracture site(s) must be reduced (translational, rotational, and angulation) before further insertion of the Ball-Tip Guide Wire. To aid in manipulation of the guide wire, bend the tip of the guide wire at an approximate angle of 10-15 degrees, 2cm from the end of the wire. Externally applied mallets and/or percutaneously inserted Spike Pushers



Fig. 16

can be used to aid reduction and guide wire insertion. Once in the distal canal, pass the wire to its final position in the epiphyseal scar.

Alternatively, the Reduction Finger may be used to assist femoral fracture reduction. To use the Reduction Finger, advance the Guide Wire and ream the proximal segment. Pass the Reduction Finger over the Ball-Tip Guide Wire. Manipulate the fracture externally while using the Reduction Finger internally to aid in fracture reduction. Once the Ball-Tip Guide Wire has passed through the fracture site, the Ball-Tip Guide Wire is advanced to the epiphyseal scar. If the Ball-Tip Guide Wire cannot advance through the fracture site, the ball tip of the guide wire should be bent slightly and then reinserted to aid in internal reduction.

Determine the proper nail length by placing a second guide wire of equal length at the greater trochanter. The length of the guide wire that is not overlapping indicates the correct nail length. Remove the second guide wire. Also, the 50cm M/DN Ruler or an ossimeter may be used.

Alternatively, the Nail Length Gauge can be used to measure the appropriate Nail length through measurement of one 100cm guide wire. To use, place a 100cm Guide Wire down the medullary canal. Slide the Nail Length Gauge over the Guide

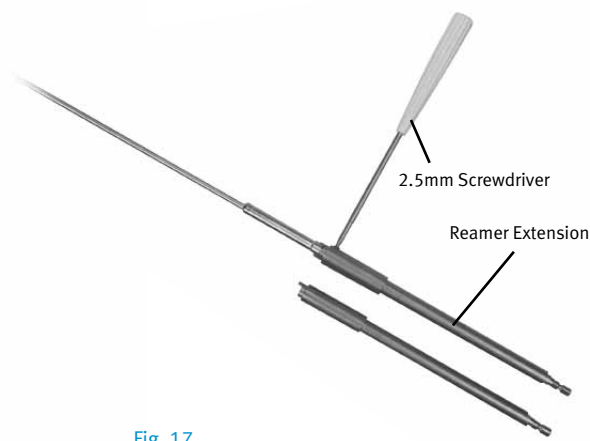

Fig. 17

Wire, ensuring that the distal portion of the gauge is resting on the piriformis fossa in order to determine correct nail length. Nail length is determined by noting the location of the remaining Guide Wire and reading the Nail Length Gauge at that particular location. If the length indicated is between two available nail sizes, it is recommended that the shorter nail be chosen.

NOTE: Nail Length Gauge can only be used with 100cm guide wire.

Using the 2.5mm Screwdriver, attach the *Pressure Sentinel*® Reamer extension (Fig. 17) to the tip of the appropriate sized *Pressure Sentinel* Reamer. Alternatively, use the Long *Pressure Sentinel* Reamers. Place the reamer through the Cannula (Fig. 18). Ream the canal over the Ball-Tip Guide Wire, in 0.5mm increments, until contact is made with the cortical wall. Continue to ream up to 1mm greater than the diameter of the selected nail.

NOTE: The proximal diameter of the 8mm and 9mm M/DN Femoral Nails is 12mm. Therefore, over ream the proximal femur to just below the level of the lesser trochanter to 13-14mm for these nail diameters. The proximal diameters of the 10mm, 11mm and 12mm M/DN Femoral Nail is 13mm.



Fig. 18

Therefore, over ream the proximal femur to just below the level of the lesser trochanter to 14mm for these nail diameters.

The *Pressure Sentinel* Intramedullary Reaming System is a system of one-piece reamers ranging in size from 5mm diameter to 27mm diameter in half millimeter increments. Each reamer is composed of a fluted reamer head, a shaft and a quick-connect drive end. The quick-connect end can be connected to a manual or powered driver. The width of the isthmus of the medullary canal is determined by preoperative x-ray examination. The instrument with the smallest possible diameter is used for initial reaming into the medullary canal. Reamers with a diameter of 5mm to 7.5mm use a 2.4mm Ball-Tip Guide Wire while reamers with a diameter of 8mm to 27mm use a 3.0mm Ball-Tip Guide Wire. As reaming continues, the reamer size should be increased by 0.5mm or 1.0mm increments until an opening of the desired size is obtained.

NOTE: To avoid reamer lodging during use, reaming should be immediately stopped and the reamers retracted when there is too much resistance.

If the reamer becomes lodged, stop reaming immediately. Reverse the direction of rotation of the handpiece and back the reamer out of the canal. The reamer can also be extracted by snapping the T-Handle Extractor onto the reamer end and then gently tapping the Extractor with a small mallet or hammer.

CAUTION: Excessive blows to the T-Handle Extractor may damage the reamer or the Extractor.

New Guide Wire Technique Option

If using a Ball-Tip Guide Wire that does NOT have a gold coated end OR if using a nail less than 10mm:

When reaming is complete and the final measurements are made, insert the Percutaneous Exchange Tube over the Ball-Tip Guide Wire (Fig. 19). Remove the Ball-Tip Guide Wire and insert a Smooth Guide Wire.

If using a Ball-Tip Guide Wire that DOES have a gold coated end and if using a nail greater than 10mm:

The Ball-Tip Guide Wire can remain in place. It is **NOT NECESSARY** to exchange the Ball-Tip Guide Wire for a Smooth Guide Wire.

NOTE: If the GUIDE WIRE becomes lodged within the reamer, use the WIRE GRIP T-Handle to push the GUIDE WIRE back into the IM canal.



Fig. 19

Guide and Nail Preparation

Select the appropriate sized *M/DN* Femoral Nail. On the back table, assemble the targeting guide to the proximal portion of the *M/DN* Femoral Nail. Determine the appropriate Right or Left Percutaneous Targeting Guide (Fig. 20). The Right Guide will accommodate the use of Right Interlocking Screws and Left “Recon” Screws, while the Left Guide will accommodate Left Interlocking Screws or Right “Recon Screws.” Confirm the correct nail/guide orientation by aligning the etched arrow on the guide, with the “ANT” etch on the anterior aspect of the nail (Fig. 21). Insert the locking bolt down the guide barrel. Use the pin wrench to tighten the locking bolt into the proximal end of the nail. The locking bolt is fully engaged when the lock washer is flattened between the locking bolt and the guide (Fig. 22).

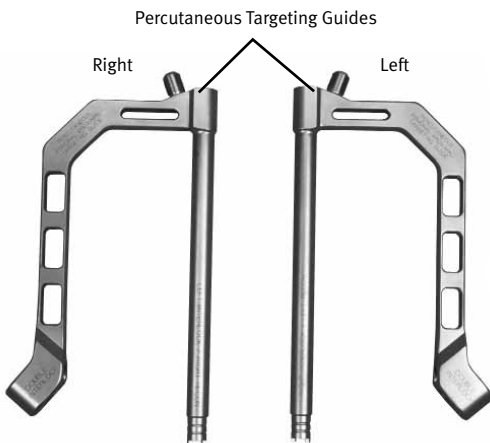

Fig. 20



Fig. 21

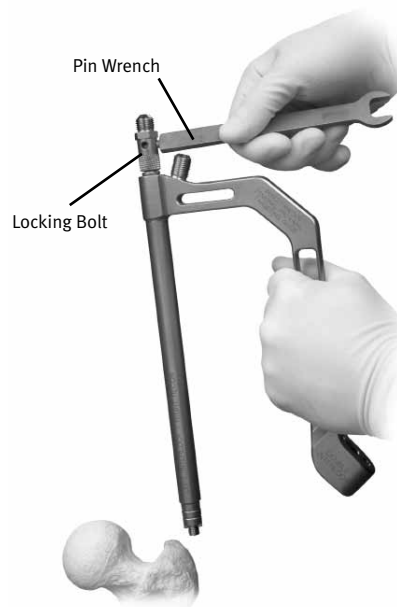

Fig. 22

Interlocking Application

Verify proper alignment of the construct by inserting the 5.0mm Femoral Drill Bushing into the 8.0mm Femoral Screw Bushing. Insert the two nested bushings through the interlocking hole. Insert the 5.0mm Drill into the bushing and through the interlocking hole. When the device is properly aligned, the drill will pass through the proximal hole of the nail and will not contact the nail (Fig. 23).

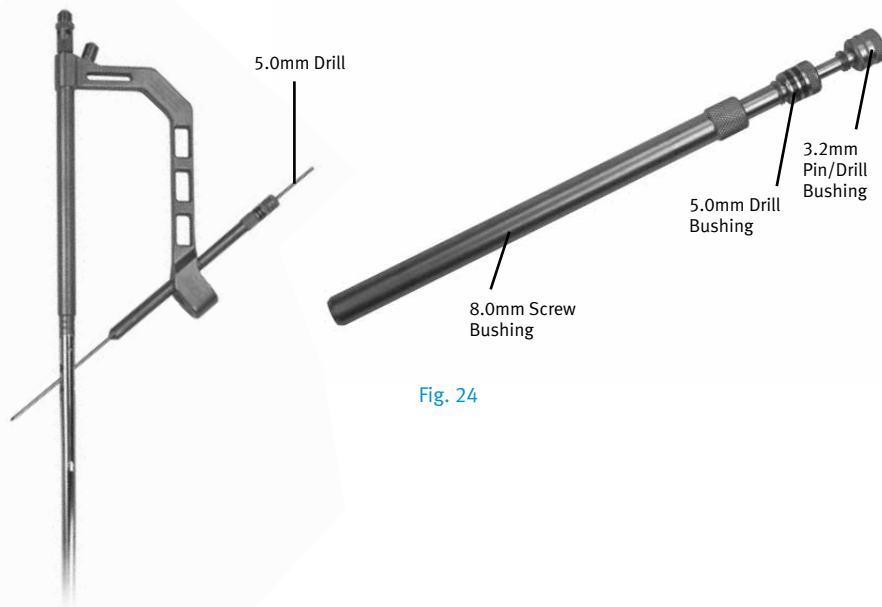

Fig. 23

Recon Application

Verify proper alignment by inserting the 3.2mm Femoral Pin/Drill Bushing into the 5.0mm Femoral Drill Bushing; then insert these two nested bushings into the 8.0mm Femoral Screw Bushing (Fig. 24). Place the three nested guide bushings through one of the recon holes in the Recon Arm. The Recon Arm is attached to the guide by placing the two fixed pins into the interlocking holes of the guide. The Targeting Guide and the Recon Arm are firmly attached

by threading on the oblique hole set screw. Insert the 3.2mm, 14-inch Percutaneous Steinmann Pin through the inner bushing. When the device is properly aligned, the Steinmann Pin will pass through the proximal hole of the nail and will not contact the nail (Fig. 25).

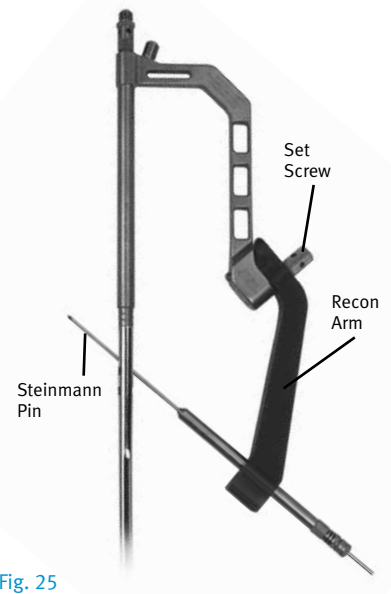

Fig. 25

Nail Insertion

Place the selected nail over the Guide Wire and into the femur. Screw the Threaded Driver, the Small Threaded Driver or the Slaphammer into the back end of the Locking Bolt. The Percutaneous Guides allow for in-line and off-axis impaction. Begin seating the nail using gentle impaction (Fig. 26). While impacting the nail, use the Targeting Guide to maintain the proper rotation during impaction.

The Slotted Mallet can also be used to drive the nail down into the canal. When used with Threaded Driver, it can be used to make slight adjustments in depth.

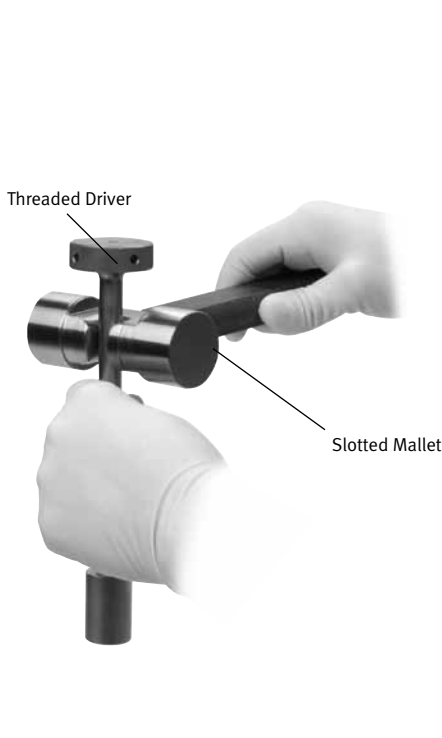

Fig. 26

NOTE: The M/DN Nail features 15 degrees of anteversion in the proximal screw holes. Based on the proximal femoral anatomy, this anteversion should improve proximal screw interlocking into the lesser trochanter (Fig. 27). Furthermore, the rotation should also improve the ease with which the distal locking screws are inserted, due to femoral condylar angulation.

When performing the Recon procedure, slide a 12.0 inch Steinmann Pin percutaneously along the anterior aspect of the trochanter, parallel to the femoral neck. Verify pin placement with the C-arm. This will help to identify the anteversion of the neck. During the insertion, the Femoral Targeting Guide must remain parallel to this



Fig. 27

pin to ensure proper anteversion for the locking screws. As previously stated, the M/DN Nail features 15 degrees of anteversion in the proximal screw holes. Based on the proximal femoral anatomy, this will improve proximal screw interlocking into the lesser trochanter. Furthermore, the rotation will improve ease of distal screw insertion because of the femoral condylar angulation. For best alignment in the femur, the reconstruction nail will need to be placed between the neutral position and 10-15 degrees of external rotation to improve screw insertion into the femoral neck and head. Use a percutaneously inserted guide pin along the anterior aspect of the femoral neck to check nail insertion rotation. The femoral guide will be inserted parallel to the guide pin.

Take great care when crossing the fracture site. Visualize the fracture in two planes with image intensification to assure proper passage of the nail into the distal fragment. Reduce the force of impaction as the proximal end of the nail approaches the greater trochanter.

If excessive resistance is encountered during nail driving, remove the nail and check the size of both the reamer and the nail. Once proper sizing has been confirmed, the surgeon may choose to over ream the canal or select a smaller size nail.

Continue to seat the nail until it is flush with the trochanter. When the nail is fully seated, remove the guide wire so that it does not get trapped in the bone. Remember, it might be concealed inside the driver or Slaphammer.

Confirm the integrity of the Locking Bolt – Nail connection and re-tighten with the Pin Wrench if necessary.

Proximal Locking (For Interlocking Application)

Screw the 5mm Femoral Drill Bushing (Color Code: Green), into the 8mm Femoral Screw Bushing, and insert them into the Percutaneous Targeting Guide. Insert the 5mm Femoral Drill (Color Code: Green), into the assembled bushings and drill until the medial femoral cortex is penetrated (Fig. 28). Remove the Drill and 5mm Femoral Drill Bushing, leaving the 8mm Femoral Screw Bushing in place.

NOTE: Make sure the drill guides pass freely through the targeting guide without wobbling. When inserting the drill guide through the skin and soft tissues, do not hit it with the mallet. Furthermore, the tip of the guide should end next to the lateral cortex. If inserted too far, the guide will angulate ANTERIOR AND PROXIMAL. This creates an errant channel for the proximal screws. Therefore, the screws will have difficulty passing through the holes in the proximal nail. If the drill passage is difficult or the drill “jumps” during insertion, the drill guide should be reinserted with attention to detail. If errant drill tracts are created in the lateral cortex, the guide should be removed. The nail should then be placed more distal or proximal to allow for an intact cortex for redrilling.

NOTE: 5.5mm Recon Screws (Color Code: Candy Stripe Green) are used proximally for all recon procedures.

3.7mm screws (Color Code: Yellow), are used distally for 8mm Femoral Nails.

4.2mm or 4.5mm screws (Color Code: Blue, Blue Stripe), are used distally for all 9mm – 11mm Femoral Nails.

5.5mm Screws (Color Code: Green), are used distally for all 12mm – 16mm Femoral Nails.



Fig. 28

Use the Proximal Screw Depth Gauge to determine screw length (Fig. 29 & 30). Once the depth is measured, the 5.5mm screw (green striped) should be inserted. Use the T-Handle Screwdriver to insert the appropriate length 5.5mm screw (Color Code: Green), to the correct reference line on the T-Handle Screwdriver Femoral Proximal Guide. Use the C-arm to check the position of the screw and tighten it appropriately (Fig. 31 & 32).

Remove the screwdriver and the 8mm Femoral Screw Bushing. Take A/P and lateral C-arm views to check for correct positioning. Once the nail is locked into position with the first screw, the same process can be repeated for the second screw. Two screws should be used to improve control of the proximal segment in varus/valgus, in rotation, and in screw purchase.

Disengage the Locking Bolt and Targeting Guide from the nail using the Pin Wrench (Fig. 33).

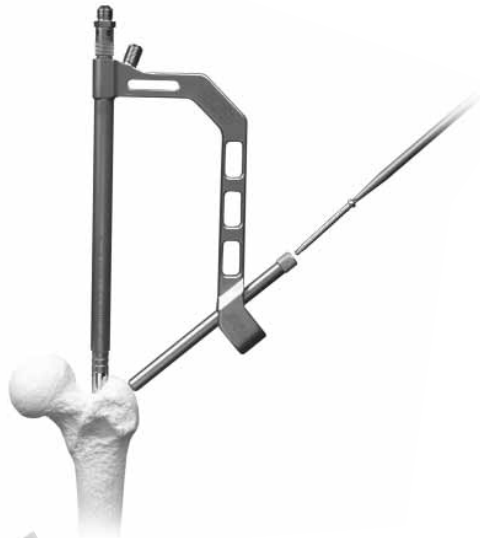

Fig. 31



Fig. 33

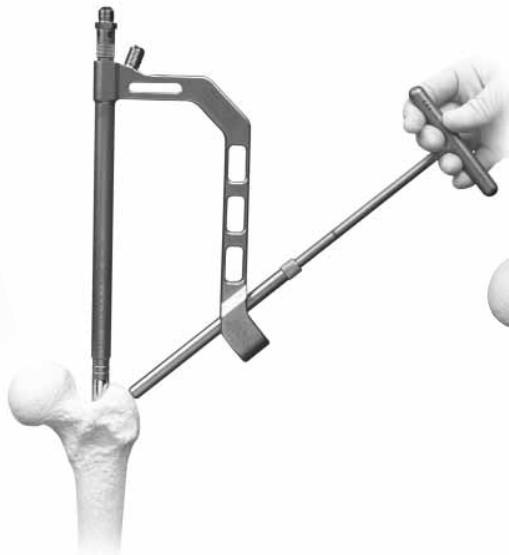

Fig. 32

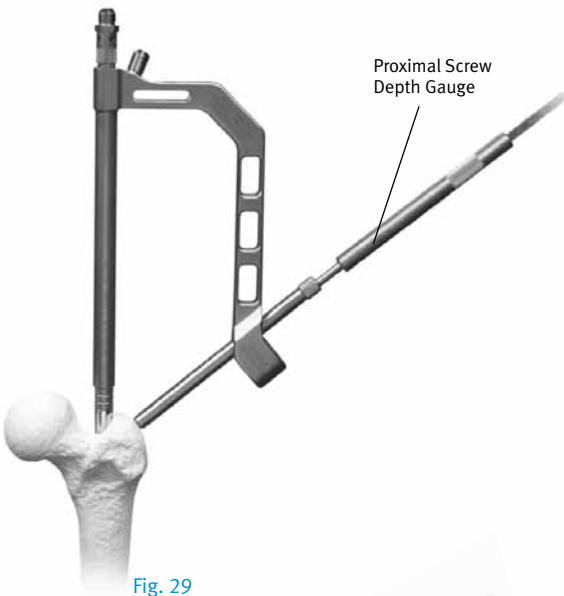

Fig. 29



Fig. 30

Proximal Locking (For Recon Application)

Correct rotation of the nail is imperative for retrograde insertion of the two screws through the nail and into the femur for the recon procedure. Be sure that the nail is inserted to the correct depth to allow placement of both screws with the correct anteversion.

Attach the *M/DN* Percutaneous Recon Arm to the Targeting Guide (Fig. 34). Re-tighten the Locking Bolt to the Nail securely using the Oblique Hole Set Screw to prevent loosening of the Guide (Fig. 35). Loosening of the Guide may produce errant drilling results. Insert the 3.2mm Proximal Pin/Drill Bushing into the 5mm Femoral Drill Bushing (Color Code: Green). Screw this construct into the 8mm Femoral Screw Bushing (Fig. 36), and insert the three assembled bushings into the inferior recon hole of the Recon Arm to the level of the skin (Fig. 37). Make an incision in the skin and fascia at this point and continue to insert the bushings until contact is made with the lateral femoral cortex. Drill the 14-inch Percutaneous Steinmann Pin into the femoral head neck to the required level to achieve fracture fragment stability, without penetrating the femoral head cortex (Fig. 38). Verify the proper position and anteversion of the pin with A/P and lateral C-arm views. Avoid excessive twisting or torquing of the Recon Arm or Targeting Guide to ensure proper targeting. If the position is not correct, remove the pin and adjust the nail rotation and/or nail depth. Verify the new pin placement with the C-arm.

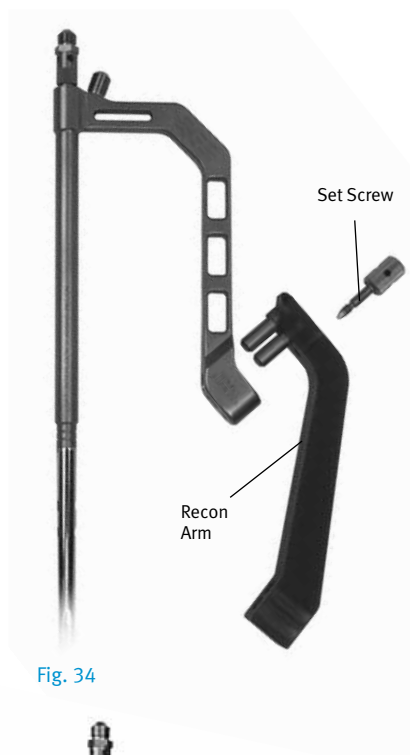

Fig. 34



Fig. 37



Fig. 35

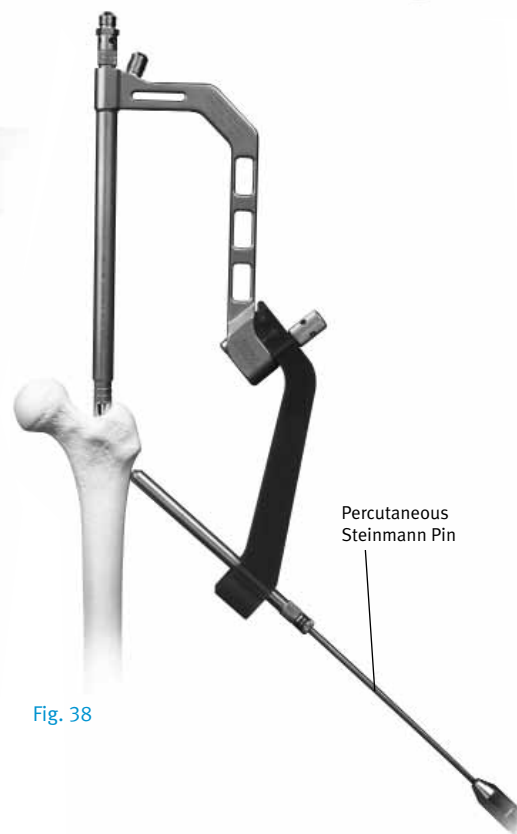

Fig. 38



Fig. 36

Assemble the second set of three bushings in the same fashion and place them into the superior hole of the Recon Arm. Drill the second 14-inch Steinmann Pin in to the bone and verify its position with the C-arm. If the position is unacceptable, remove both Steinmann Pins and reposition the nail. If the correct position is obtained, remove the Threaded Driver or Slaphammer. Also remove the inferior Steinmann Pin and the 3.2mm Pin/Drill Bushing.

Insert the 5mm Femoral Drill (Color Code: Green), into the 5mm Femoral Drill Bushing (Color Code: Green). Drill the inferior proximal screw hole while monitoring image intensification to prevent penetration of the femoral head. Ensure bushings are contacting lateral cortex of femur. Read the appropriate screw length directly from the calibrated Femoral Drill at the backend of the bushings (Fig. 39). Remove the 5mm Drill and Femoral Drill Bushing. Insert the Recon Screw Counterbore through the outer/8mm Femoral Screw Bushing and Counterbore. The blunt end of the Counterbore serves as a stop.

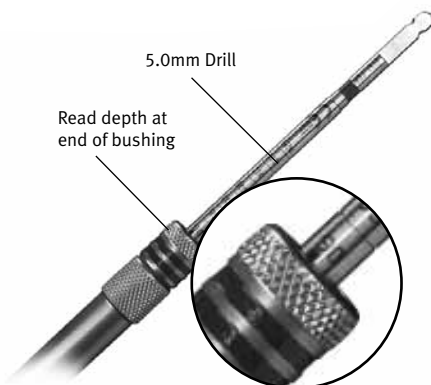

Fig. 39

Screw length may alternatively be measured using the Proximal Screw Depth Gauge. Select a screw equal to the measured length to avoid penetration of the joint.

Another gauge that can be used to measure screw length is the Cannulated Depth Gauge. Slide the Cannulated Depth Gauge over the Steinmann Pin, i.e., the inferior of the two Steinmann Pins if two pins are used, until the gauge contacts the lateral aspect of the femur. Assess that the gauge is seated against the bone using the C-arm. Read and record the length of the Steinmann Pin from the calibrated depth gauge.

NOTE: This measurement designates the correct length of the screw to be implanted.

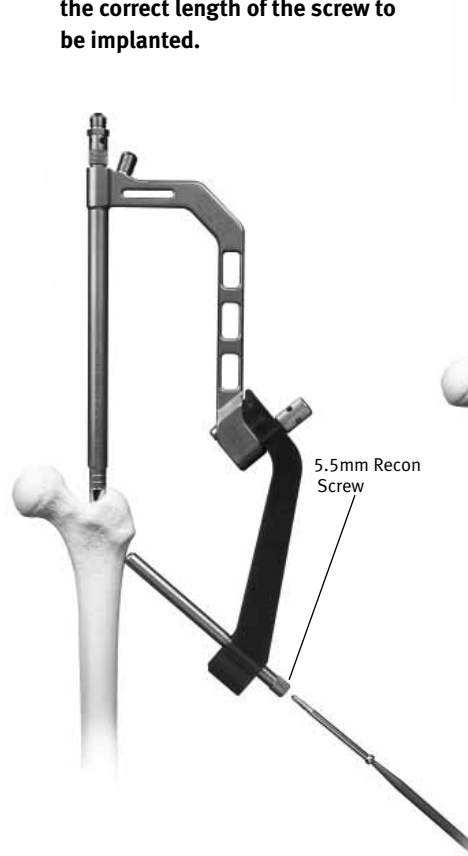

Fig. 40

Remove the Counterbore. Insert the appropriate length 5.5mm Partially Threaded Recon Screw through the outer bushing (Fig. 40) to the level of the correct reference line on the T-Handle Screwdriver (Fig. 41). Use the C-arm to ensure proper seating of the locking screw well within the femoral head. Tighten it appropriately.

The first screw should lie in the inferior neck to allow room for the second screw to be placed. This may be difficult in small patients or in patients with varus hips. Be certain to seat the inferior screw tightly against the medial cortex to prevent varus deformity and to allow for placement of the proximal screw.

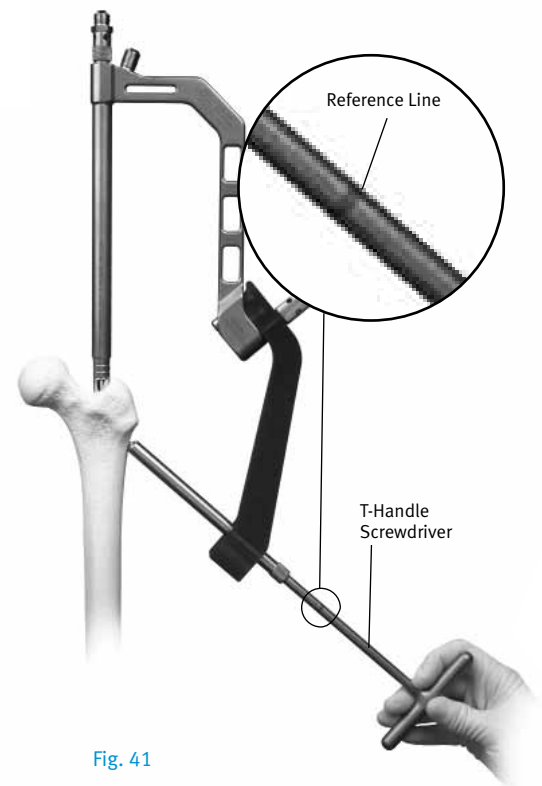

Fig. 41

Remove the T-Handle Screwdriver and the Femoral Bushing. Take A/P and lateral C-arm views to check for correct positioning. Repeat the same procedures for insertion of the superior locking screw. Again, observe A/P and lateral C-arm views to ensure proper seating within the femoral head and neck. In small stature individuals, the neck width should be measured preoperatively to assure for proper dual screw insertion. If the neck width is too narrow, a single screw-locked reconstruction nail or another implant should be inserted. Using the Pin Wrench, loosen and remove the Recon Arm, the Locking Bolt and Targeting Guide (Fig. 42).



Fig. 42

Nail Cap Placement

Using the Percutaneous Nail Cap Inserter, place an *M/DN* Nail Cap of the appropriate length (0mm, 5mm, 10mm, 15mm) in the proximal nail (Fig. 43). These caps help protect the internal threads of the nail, facilitate future extraction, and allow the surgeon to adjust the length of the nail.

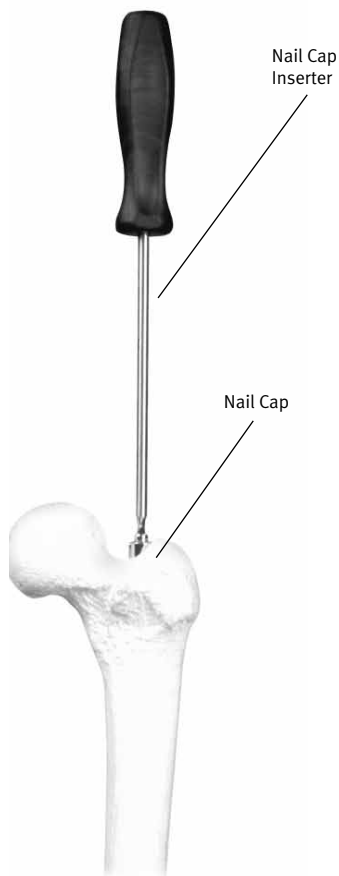

Fig. 43

Distal Interlocking

Distal screw preparation may be performed with a freehand technique using the Free-Hand Targeting Device (Fig. 44). Use the appropriate sized combination trocar/drill for the distal screw size/color. Use the yellow drill (3.2mm) for the 3.7mm screw (also yellow) in the 8mm nail size. Use the blue colored drill (3.7mm) and screws (4.2mm or 4.5mm) for nails with a 9mm to 11mm diameter. With nails of 12mm and larger, use the green colored drills (5mm) and screws (5.5mm).

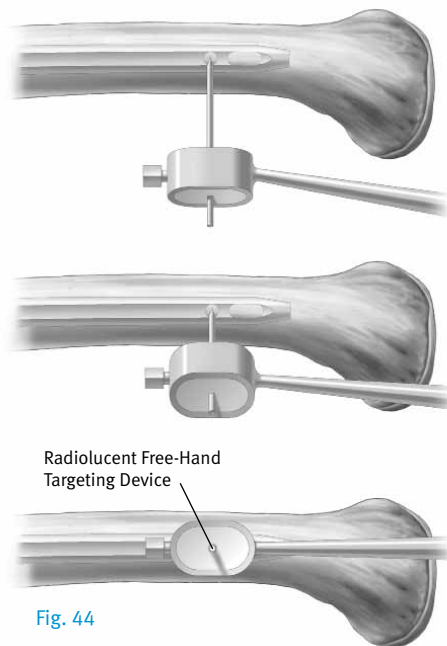

Fig. 44

Insert the combination trocar/drill into the radiolucent Freehand Targeting Device. The distal angle of the Targeting Device should point toward the patient. This will give the Device a larger arc of motion when creating the fluoroscopic insertion site.

The proximal target and distal interlocking holes are for static and dynamic interlocking, respectively. If a potential exists for initial static locking followed by dynamic locking, insert both distal screws. If a segmental bone defect is present or there is potential for early weight bearing, insert both of the distal interlocking screws! Identifying the correct insertion alignment and angle requires proper C-arm and leg positioning. Therefore, the leg may need to be abducted in order to create the correct line of viewing. Position the C-arm so that the locking hole of the nail appears perfectly round on the C-arm monitor (Fig. 45). In addition, place the C-arm receptor as close as possible to the medial aspect of the distal femur. This will allow for ample space for drill and screwdriver positioning.

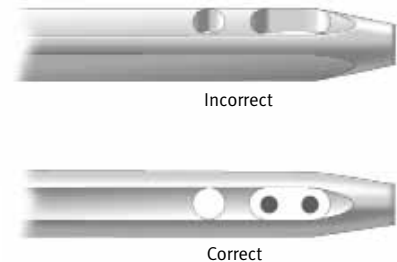

Fig. 45

The correct incision site is determined by placing the tip of the trocar in line with the interlocking hole while viewing with the C-arm. Make a lateral stab wound opposite the appropriate locking hole. Use blunt dissection until the lateral osseous cortex is palpated with a hemostat. Place the tip of the trocar onto the cortex and move the tip until it is centered over the interlocking hole (Fig. 46). Move the trocar in one plane (anterior-posterior or proximal-

distal) at a time, while checking each movement with C-arm imaging. Once the trocar is perfectly in line with the C-arm beam and completely in the center of the interlocking hole, tap the tip of the trocar with a mallet to engage the lateral cortex. This minimizes the risk of losing the starting site when initiating drilling.

Drill with the pilot point distal drill until the medial cortex is penetrated (Fig. 47). As a suggestion, each barrier

of engagement (i.e., lateral cortex, nail hole, and medial cortex) should be checked by the C-arm in order to avoid errant drilling and subsequent screw insertion. Furthermore, the drill position should be confirmed with A/P imaging (especially with the dynamic screw insertion). Once the drill is correctly inserted, remove it, and insert the Distal Screw Depth Gauge (Fig. 48).

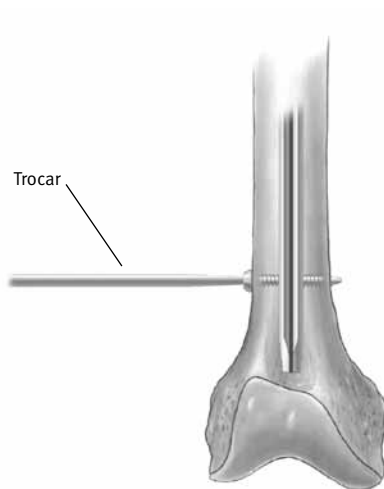

Fig. 46

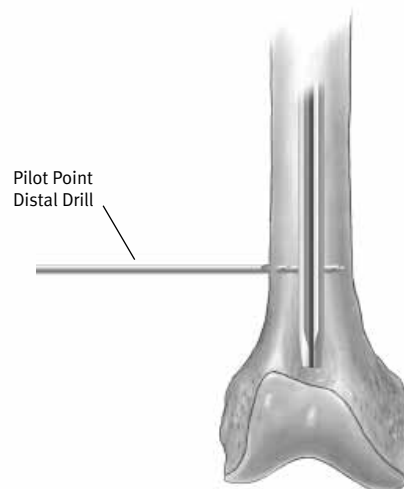

Fig. 47

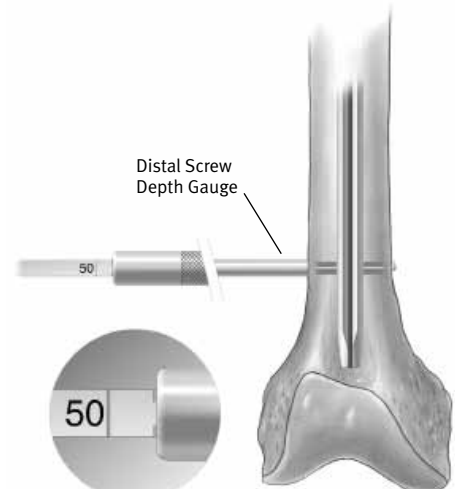

Fig. 48

Select an appropriate screw to ensure adequate engagement of the medial cortex. (If in between sizes, round up to the next available length.) Once the length is determined, insert the appropriate size screw (Fig. 49). Again, confirm screw placement with bi-planar fluoroscopy. Repeat the same process when inserting two distal interlocking screws (Fig. 50).

If extreme obesity or muscularity is present, use a hemostat or suture around the neck of the screw in order to aid removal when errant insertion is noted.

Incision Closure

Irrigate the incision to remove hematoma and osseous debris. No drains or suction closure devices are needed. Close the incisions with steri-strips, subcutaneous suture, interrupted suture, or staples. Cover the incisions with sterile dressings. If extreme abduction is required for appropriate distal interlock fluoroscopic visualization, the proximal entry site incision should be closed first. Closing the incision will reduce the risk of having drapes migrate close to the incision.

Extraction

Should extraction of the nail become necessary, attach the Threaded Extractor to the end of the nail and use the Slaphammer to extract the nail.

NOTE: The cannulated Locking Bolt should not be used for nail removal. Extraction of the nail should be accomplished by using the Threaded Extractor.

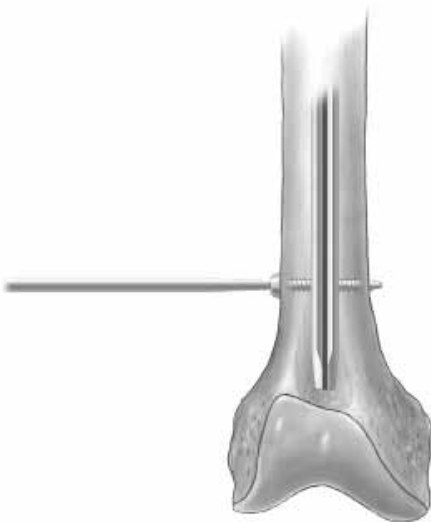

Fig. 49

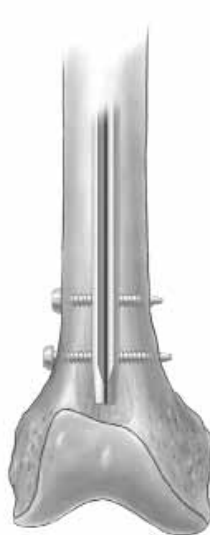

Fig. 50

Instrument Case

M/DN Instruments

Option A (Metal Femoral/MIS Femoral/Retrograde)

Set Number 00-2255-000-17 (includes case/tray/lid + instruments)

Case Set Number 00-2237-090-00 (includes trays and lid)

Metal Femoral Guides/Instruments (top tray holds the following)

Prod. No.	Description	
00-2255-001-03	Locking Bolt Assembly	2
00-2255-002-10	Fem. Prox. Targeting Guide	1
00-2255-002-11	Fem. Prox. Targeting Guide	1
00-2255-004-32	3.2mm Pin Bushing	2
00-2255-004-50	5.0mm Drill Bushing	2
00-2255-004-80	8.0mm Screw Bushing	2
00-2255-011-00	Recon Screw Counterbore	1
00-2258-067-00	ITST® Threaded Guide Pin 355mm	3
00-2255-028-00	Pin Wrench	1
00-2255-035-50	5.0mm Femoral Drill, Large	3

Guides (middle tray holds the following; must be used with above tray)

Prod. No.	Description	
00-2255-003-03	Perc. Recon Arm Set Screw	2
00-2255-028-00	Pin Wrench	1
00-2255-050-01	Fem. Perc. Targeting Guide	1
00-2255-050-02	Fem. Perc. Targeting Guide	1
00-2255-051-00	Perc. Recon Arm	1
00-2255-053-00	Perc. Cannula	1
00-2255-054-00	Perc. Centering Bushing	1
00-2255-058-00	Per. Locking Bolt	2

Retrograde Femoral Instruments (base of case holds the following)

Prod. No.	Description	
00-2241-001-00	Retro. Targ. Guide Assembly (4 pcs.)	1
00-2241-001-01	Adj. Targ. Arm Assembly (5 pcs.)	1
00-2241-006-00	Cortical Nut Screwdriver	1
00-2241-008-37	3.7mm Drill Bushing	2
00-2241-008-50	5.0mm Drill Bushing	2
00-2258-067-00	ITST Threaded Guide Pin 355mm	3
00-2255-001-00	Locking Bolt	2
00-2255-004-80	8.0mm Screw Bushing	2
00-2255-028-00	Pin Wrench	1
00-2255-031-37	3.7mm Drill	1
00-2255-035-50	5.0mm Drill, Large	1
00-2255-059-00	Nail Cap Inserter (captured screwdriver)	1

Option B

Prod. No.	Description
2255-000-06	<i>M/DN Percutaneous Instrument Set (contains 1 each of the following unless otherwise indicated)</i>
2228-097-00	Pressure Sentinel Diameter Gauge
2237-001-07	Femoral Awl, 7mm
2237-005-00	Mallet 3 lb.
2237-042-00	Threaded Driver
2255-009-00	Slaphammer
2237-053-00	Wire Grip T-Handle
2237-054-00	Screw Depth Gauge
2237-055-00	Ruler
2246-023-00	On Guide Pin 3.2mm Dia. x 12in.
2246-062-00	Reversed Tibial Awl
2246-063-01	Offset Driver Adaptor
2255-005-32	<i>M/DN Fem Pin/Drill Bushing 3.2mm (2 each)</i>
2255-005-50	<i>M/DN Femoral Drill Bushing 5.0mm (2 each)</i>
2255-005-80	<i>M/DN Fem Screw Bushing 8mm (2 each)</i>
2255-007-50	<i>M/DN Bushing Awl 5.0mm Diameter</i>
2255-011-00	<i>M/DN Recon Screw Counter Bore</i>
2255-012-33	<i>M/DN Distal Trocar Med 3.2mm</i>
2255-012-37	<i>M/DN Distal Trocar 3.7mm</i>
2255-012-50	<i>M/DN Distal Trocar 5.0mm</i>
2255-013-00	<i>M/DN T-Handle HXHD Screwdriver 3.5mm</i>
2255-013-01	<i>M/DN Distal Screwdriver 3.5mm Hex</i>
2255-014-00	<i>M/DN Threaded Extractor (2 each)</i>
2255-015-01	<i>M/DN Distal Insert</i>
2255-015-02	<i>M/DN Set Screw</i>
2255-015-03	<i>M/DN Handle</i>
2255-016-00	<i>M/DN Fem Awl 7mm Dia. Angled Tip</i>
2255-018-00	<i>M/DN Distal Screw Depth Gauge</i>
2255-020-00	<i>M/DN T-Handle Ratchet Screwdriver</i>
2255-027-00	<i>M/DN Locking Bolt Wrench</i>
2255-028-00	<i>M/DN 9/16 in. Pin Wrench</i>
2255-031-50	Femoral Drill 5.0mm
2255-033-32	Pilot Tip Distal Drill 3.2mm
2255-033-37	Pilot Tip Distal Drill 3.7mm
2255-033-50	Pilot Tip Distal Drill 5.0mm
2255-040-00	<i>M/DN Perc Fem Inst Case Assy</i>

2255-045-00	<i>M/DN Perc Genl Inst Case Assy</i>
2255-050-01	<i>M/DN Perc Targeting Guide, L</i>
2255-050-02	<i>M/DN Perc Targeting Guide, R</i>
2255-051-00	<i>M/DN Percutaneous Recon Arm</i>
2255-052-00	<i>M/DN Percutaneous Starter RMR</i>
2255-053-00	<i>M/DN Percutaneous Cannula</i>
2255-054-00	<i>M/DN Perc Centering Bushing</i>
2255-055-00	<i>M/DN Percutaneous Steinman Pin</i>
2255-056-00	<i>M/DN Perc Exchange Tube</i>
2255-057-00	<i>M/DN Press Sent RMR Extension (2 each)</i>
2255-058-00	<i>M/DN Extra Long Locking Bolt</i>
2255-059-00	<i>M/DN Perc Nail Cap Inserter</i>
2255-06-000	<i>M/DN Perc Trochanteric Reamer</i>
2305-024-00	Small 2.5mm Hexhead Screwdriver
2255-003-03	Set Screw

Prod. No.	Description
2255-000-07	<i>M/DN Percutaneous Add On Instrument Set (contains 1 each of the following unless otherwise indicated)</i>
2255-003-03	<i>M/DN Oblique Hole Set Screw</i>
2255-035-00	<i>M/DN Perc Fem Inst Case Assy</i>
2255-050-01	<i>M/DN Perc Targeting Guide, L</i>
2255-050-02	<i>M/DN Perc Targeting Guide, R</i>
2255-051-00	<i>M/DN Percutaneous Recon Arm</i>
2255-052-00	<i>M/DN Percutaneous Starter RMR</i>
2255-053-00	<i>M/DN Percutaneous Cannula</i>
2255-054-00	<i>M/DN Perc Centering Bushing</i>
2255-055-00	<i>M/DN Percutaneous Steinman Pin</i>
2255-056-00	<i>M/DN Perc Exchange Tube</i>
2255-057-00	<i>M/DN Press Sent RMR Extension (2 each)</i>
2255-058-00	<i>M/DN Extra Long Locking Bolt</i>
2255-059-00	<i>M/DN Perc Nail Cap Inserter</i>
2255-006-00	<i>M/DN Perc Trochanteric Reamer</i>
2350-024-00	Small 2.5mm Hexhead Screwdriver
2255-009-00	Slaphammer

General Instrument Set

Set Number 00-2255-000-16 (includes case/tray/lid + instruments)

Case Set Number 00-2237-095-00 (includes trays and lid)

General Instruments (top tray holds the following)

Prod. No.	Description	
00-2237-053-00	Wire Grip T-Handle	1
00-2237-061-00	Long T-Handle Cannulated Awl	1
00-2237-066-00	Short T-Handle Cannulated Awl	1
00-2255-016-00	7mm Angled Femoral Awl*	1
00-2255-034-00	Reduction Finger	1
00-2255-052-00	9mm/14mm Perc. Tapered Reamer	1
00-2255-060-00	8mm Trochanteric Reamer	1
00-2258-067-00	ITST Threaded Guide Pin 355mm	3
00-2255-038-00	T-Handle	1
00-4816-060-00	Ball-Spiked Pusher	1
00-4817-011-00	Shoulder Hook	1

General Instruments (middle tray holds the following)

Prod. No.	Description	
00-2228-097-00	Diameter Gauge	1
00-2237-055-00	Ruler	1
00-2255-057-00	Flexible Reamer Extension	2
00-2305-024-00	Screwdriver, Small Hexhead	1
00-2237-060-00	Slotted Mallet	1
00-2237-062-00	Threaded Driver	1
00-2237-063-00	Screw Depth Gauge, Long	1
00-2255-013-00	Screwdriver 3.5mm Hex, Long	1
00-2255-017-00	Flared Exchange Tube	1
00-2237-064-00	Nail Length Gauge	1
00-2258-057-00	Cannulated Depth Gauge	1

General Instruments (base of case holds the following)

Prod. No.	Description	
00-2255-009-00	Slaphammer	1
00-2255-028-00	Pin Wrench	1
00-2237-065-00	Threaded Extractor (17cm)	1
00-2237-065-01	Threaded Extractor (32cm)	1
00-2255-012-33	3.2mm Trocar	3
00-2255-012-37	3.7mm Trocar	3
00-2255-012-50	5.0mm Trocar	3
00-2255-033-32	3.2mm Drill	3
00-2255-033-37	3.7mm Drill	3
00-2255-033-50	5.0mm Drill	3
00-2255-018-00	Distal Screw Depth Gauge	1
00-2255-013-01	Distal Screwdriver 3.5mm Hex	1
00-2255-015-03	Wand Handle	1
00-2255-015-01	Wand Insert	1
00-2255-015-02	Wand Set Screw	1

* The 7mm Straight Awl (00-2237-001-07) OR the 7mm Angled Femoral Awl (00-2255-016-00) will fit in the case. However, when you order the set number (00-2255-000-16), you will get the Angled Awl.

Pressure Sentinel Intramedullary Reaming System Order Information

Prod. No.	Description
00-2218-000-00	Long Pressure Sentinel Reamers Tray/Case/Lid
Includes the following instruments & case:	
00-2218-008-00	8.0mm Long Flexible PS Reamer
00-2218-008-05	8.5mm Long Flexible PS Reamer
00-2218-009-00	9.0mm Long Flexible PS Reamer
00-2218-009-05	9.5mm Long Flexible PS Reamer
00-2218-010-00	10.0mm Long Flexible PS Reamer
00-2218-010-05	10.5mm Long Flexible PS Reamer
00-2218-011-00	11.0mm Long Flexible PS Reamer
00-2218-011-05	11.5mm Long Flexible PS Reamer
00-2218-012-00	12.0mm Long Flexible PS Reamer
00-2218-012-05	12.5mm Long Flexible PS Reamer
00-2218-013-00	13.0mm Long Flexible PS Reamer
00-2218-013-05	13.5mm Long Flexible PS Reamer
00-2218-014-00	14.0mm Long Flexible PS Reamer
00-2218-014-05	14.5mm Long Flexible PS Reamer
00-2218-015-00	15.0mm Long Flexible PS Reamer
00-2218-015-05	15.5mm Long Flexible PS Reamer
00-2218-016-00	16.0mm Long Flexible PS Reamer
00-2218-016-05	16.5mm Long Flexible PS Reamer
00-2218-017-00	17.0mm Long Flexible PS Reamer
00-2218-017-05	17.5mm Long Flexible PS Reamer
00-2218-018-00	18.0mm Long Flexible PS Reamer
00-2228-030-00	T-Handle Extractor
00-2228-097-00	Diameter Gauge
00-5044-012-00	Adapter 3 Jaw Chuck
00-2228-098-10	Soak Tray
00-2218-025-00	Long Cleaning Brush*
00-2218-030-00	Torque Limiter
00-2237-075-00	Long Reamer/Instrument Case Assembly
00-2237-076-00	Long Reamer/Instrument Case Base
00-2237-077-00	Long Reamer/Instrument Case Lid
00-2237-078-00	Long Reamer/Instrument Top Tray (8mm-13.5mm)
00-2237-079-00	Long Reamer/Instrument Middle Tray

*Non-sterile

00-2228-000-00 Pressure Sentinel Reamer Full Set

Includes the following instruments & case:

00-2228-005-00	5.0mm Flexible Reamer
00-2228-005-05	5.5mm Flexible Reamer
00-2228-006-00	6.0mm Flexible Reamer
00-2228-006-05	6.5mm Flexible Reamer
00-2228-007-00	7.0mm Flexible Reamer
00-2228-007-05	7.5mm Flexible Reamer
00-2228-008-00	8.0mm Flexible Reamer
00-2228-008-05	8.5mm Flexible Reamer
00-2228-009-00	9.0mm Flexible Reamer
00-2228-009-05	9.5mm Flexible Reamer
00-2228-010-00	10.0mm Flexible Reamer
00-2228-010-05	10.5mm Flexible Reamer
00-2228-011-00	11.0mm Flexible Reamer
00-2228-011-05	11.5mm Flexible Reamer
00-2228-012-00	12.0mm Flexible Reamer
00-2228-012-05	12.5mm Flexible Reamer
00-2228-013-00	13.0mm Flexible Reamer
00-2228-013-05	13.5mm Flexible Reamer
00-2228-014-00	14.0mm Flexible Reamer
00-2228-014-05	14.5mm Flexible Reamer
00-2228-015-00	15.0mm Flexible Reamer
00-2228-015-05	15.5mm Flexible Reamer
00-2228-016-00	16.0mm Flexible Reamer
00-2228-016-05	16.5mm Flexible Reamer
00-2228-017-00	17.0mm Flexible Reamer
00-2228-017-05	17.5mm Flexible Reamer
00-2228-018-00	18.0mm Flexible Reamer
00-2228-018-05	18.5mm Flexible Reamer
00-2228-019-00	19.0mm Flexible Reamer
00-2228-019-05	19.5mm Flexible Reamer
00-2228-020-00	20.0mm Flexible Reamer
00-2228-020-05	20.5mm Flexible Reamer
00-2228-021-00	21.0mm Flexible Reamer
00-2228-021-05	21.5mm Flexible Reamer
00-2228-022-00	22.0mm Flexible Reamer
00-2228-030-00	T-Handle Extractor
00-2228-097-00	Diameter Gauge
00-2228-098-00	Soak Tray
00-5044-012-00	1/4in. Jacob's Chuck to Zimmer Adapter, Qty=2
00-2228-090-00	Sterilization Case

Optional Reamer Sizes

Prod. No.	Description
00-2228-022-05	22.5mm Flexible Reamer
00-2228-023-00	23.0mm Flexible Reamer
00-2228-023-05	23.5mm Flexible Reamer
00-2228-024-01	24.0mm Flexible Reamer
00-2228-024-05	24.5mm Flexible Reamer
00-2228-025-01	25.0mm Flexible Reamer
00-2228-025-05	25.5mm Flexible Reamer
00-2228-026-01	26.0mm Flexible Reamer
00-2228-026-05	26.5mm Flexible Reamer
00-2228-027-01	27.0mm Flexible Reamer

Pressure Sentinel Reamer Sets

Prod. No.	Description
00-2228-000-01	Pressure Sentinel Reamer Trauma Set Includes the following instruments & case: 5.0mm, 6.0mm, 7.0mm & 8.00mm- 17.5mm Flexible Reamers in .5mm increments (1ea.)
00-2228-030-00	T-Handle Extractor
00-5044-012-00	1/4in. Jacob's Chuck to Zimmer Adapter, Qty=2
00-2228-090-00	Sterilization Case
00-2228-000-02	Pressure Sentinel Reamer Hip Set Includes the following instruments & case: 8.0mm- 18.0mm Flexible reamers in 1mm increments (1ea.)
00-2228-030-00	T-Handle Extractor
00-5044-012-00	1/4in. Jacob's Chuck to Zimmer Adapter, Qty=1
00-2228-090-00	Sterilization Case

00-2228-000-03	Pressure Sentinel Reamer Expanded Hip Set Includes the following instruments & case: 8.0mm-18.0mm Flexible reamers in .5mm increments (1ea.)
00-2228-030-00	T-Handle Extractor
00-5044-012-00	1/4in. Jacob's Chuck to Zimmer Adapter, Qty=1
00-2228-090-00	Sterilization case
00-2228-90-00	Sterilization Case Includes the following components:
00-2228-091-00	Base
00-2228-092-00	18.0mm to 22.0mm Reamer Tray
00-2228-093-00	12.0mm to 17.5mm Reamer Tray
00-2228-094-00	5.0mm to 11.5mm Reamer Tray
00-2228-096-00	Case Lid
00-9975-011-00	Pressure Sentinel Reamer ZMR® Hip Set Includes the following components: 8.0mm-27.0mm Flexible reamers in .5mm increments (1ea.)
00-9965-081-10	ZMR Flexible Reamer Diameter Gauge
00-9975-099-00	Case Lid
00-2228-040-00	ZMR Flexible Reamer Metal Case
<i>* Set includes case and contents without the 00-9975-099-00 Case Lid. The Case Lid must be ordered separately.</i>	

Optional Instruments

Prod. No.	Description
00-2255-008-00	Guide Wire 2.4mm, Ball-Tip, 70cm box (required for 5.0mm-7.5mm Pressure Sentinel Reamers)
47-2255-008-01	Guide Wire 3.0mm, Ball-Tip, 100cm Sterile/box (required for 8.0mm and larger Pressure Sentinel Reamers)
00-2255-008-01	Guide Wire 3.0mm, Ball-Tip, 100cm Non-sterile/box (required for 8.0mm and larger Pressure Sentinel Reamers)

1 Brumback RJ, Toal Jr TR, Murphy-Zane M et al. Immediate Weight-Bearing After Treatment of a Comminuted Fracture of the Femoral Shaft with a Statically Locked Intramedullary Nail. *J Bone Joint Surg.* 1999; 81A : 1538.



This documentation is intended exclusively for physicians and is not intended for laypersons. Information on the products and procedures contained in this document is of a general nature and does not represent and does not constitute medical advice or recommendations. Because this information does not purport to constitute any diagnostic or therapeutic statement with regard to any individual medical case, each patient must be examined and advised individually, and this document does not replace the need for such examination and/or advice in whole or in part. Please refer to the package inserts for important product information, including, but not limited to, contraindications, warnings, precautions, and adverse effects.

CE
0086

Contact your Zimmer representative or visit us at www.zimmer.com

The CE mark is valid only if it is also printed on the product label.

